



We manage heat®

Deice System for 4.5 Meter Antenna, half, 240v Patriot

Installation and Operation Manual

ENVIRONMENTAL TECHNOLOGY, INC.

1302 High Street

South Bend, Indiana 46601

(219) 233-1202 or (800) 234-4239

FAX (219) 233-2152 or (888) 234-4238

www.networketi.com

Instruction Manual # 18723 for Deice System for 4.5 Meter Antenna, half, 240v (PAT)

Materials Supplied

Before disposing of the packing material, verify the inclusion of items below in the packing list for the system purchased. Immediately notify customer service of any discrepancy or shipping damage.

Quantity	Part Number	Packing List Description
1	17540	APS-4, 240Vac
1	18688	CIT-1 Junction Box Assembly
8	18640	42 ft. heater tape
4	18684	Heater Tape Power Cable
1	18685	Power Distribution Junction Box
2	18724	Power Cable
3	18703	Wire Nut
1	18719	Wire Nut
10 ft	18323	Foil Tape (for patching)
1	18722	Heater Tape Layout Diagram
1	18723	Manual, Instruction
12	18771	Tie Wraps
1	18725	Feedhorn Heater
1	19336	Sensor Mounting Kit
1	19337	Distribution Box Mounting Kit
1	19338	APS-4 Mounting Kit
4	18763	Linking Connector

Before you get started here is a list of tools and supplies needed to completely mount this deice system.

TOOLS:

Slotted standard screw driver (small and large)	Phillips Screw Driver (small and large)
Clean Cloth Rags or Paper Towels	Isopropyl (Rubbing) Alcohol (90%)
Ruler or Measuring Device	Knife
Aerosol cooling spray	2 oz. of water
Adjustable wrench	Permanent Magic Marker
Duct tape (optional)	Pliers

NOTE: ETI suggests mounting both the junction box and APS-4 on the antenna post. The CIT-1 should be mounted out along the feed arm or on the front, side or top of the reflector. Mount the sensor securely in upright position above or far enough away from the reflector so as not to be protected from the falling snow. Mounting in the front or on the side will provide service access.

Read these instructions carefully and follow all procedures for installation of system components. Electrical wiring must be performed in accordance with the appropriate electrical codes.

CLEANING THE REFLECTOR

1. If the back surface of the antenna is very dirty (i.e., visibly darkened with dirt or film), first wash it with soap and water or other cleaning agent and then rinse thoroughly with water and allow it to dry before cleaning with isopropyl alcohol.
2. Wipe clean the lower half of the back surface of the antenna using copious amounts of isopropyl alcohol and paper towels. The 90 % (or better) isopropyl alcohol solution will produce the best results.

NOTE: *It is important that the alcohol always be used as the last cleaning step because the rear antenna surface must not have any residue from other cleaning agents on it prior to the point of applying the heater tape. Isopropyl alcohol will evaporate completely leaving no residue, whereas other cleaning agents may leave a film of residue which could potentially affect the ability of the tape to properly adhere to the antenna surface.*

NOTE: *A minimum ambient temperature of 45 deg. F is required for the tape to achieve proper bonding. Note that the ambient temperature requirement applies to both the surrounding air as well as the dish surface.*

INSTALLING DE-ICE SYSTEM COMPONENTS UNDER DIFFICULT ENVIRONMENTAL CONDITIONS

Certain environmental conditions such as cold temperatures and high winds will pose problems when installing system components. These conditions will not only be unpleasant for the installer, but some system components, such as the heater tape, may not be able to be applied properly.

If the ambient temperature of the antenna is too low to achieve proper tape bonding, a heated tent can be put together using clear plastic sheeting and a propane-fired portable heater (or, "Salamander"). A sheet thickness of 0.004" is sufficient for constructing a tent. However, high winds and cold temperatures may impede the construction of the tent. If wind velocities exceed the range of 10 to 15 m.p.h., the force on the plastic exerted by the wind will make it very difficult to drape and appropriately anchor the sheets. If adhesive tape is being used to fasten the plastic sheets to the antenna or other fixed surfaces, or to attach sections of sheets together, cold outdoor temperatures may have the same adverse affect on bonding as with the heater tape. If adhesion is a problem in the tape used to anchor the plastic sheets, use weighted objects to hold the plastic in place where appropriate.

For antenna heater systems with backcovers (optional), windy conditions may also impede the backcover installation. Again, the force of high winds may make manipulation and attachment of the backcover difficult. If a tent has been constructed, it can act as a wind break during attachment of the backcover, if it is being attached inside the tent.

TAPING ON THE HEATERS

Once the back surface of the antenna is thoroughly clean and dry, the heater tape is ready to be applied. All adhesives require appropriate environmental conditions to achieve conformance to the bonding surface and proper curing. The adhesive on the heater tape is no exception. The heater tape adhesive is formulated to conform and bond at lower temperatures, but application in too cold of an ambient temperature will prevent the adhesive from conforming to the antenna surface, resulting in a poor tape bond. A minimum ambient temperature of 45 deg. F is required for the tape to achieve proper bonding. Note that the ambient temperature requirement applies to both the surrounding air as well as the dish surface. Tape bonding conditions will

improve the closer ambient temperature is to room temperature (temperatures above room temperature are also favorable).

BEFORE APPLYING THE HEATERS

The entire heater tape set consists of 8 individual heater tapes. Note that the figures with the electrical connections for the heater tapes show 4 separate groups of heater tapes, where each group consists of 2 heater tapes connected in series. The series connection between the two tapes in each group is made using a linking connector (see Figure # 5). Each linking connector, made from 3 individual 12" long connector pairs, is included so that the electrical connection can be made between tapes while jumping over the support ribs which isolate each panel/segment. Each group of 2 heater tapes will join in a complementary manner (i.e., male connector to female connector) to the linking connector. It does not matter if a male or female connector is located at the starting end of a group because the order in this case is accommodated when each heater tape group gets connected to its respective power cable.

3. Refer to the layout diagram as shown in Figure 1 for the appropriate spacing pattern for the tape. A layout template is supplied to assist with locating key points and bends on the antenna surfaces where the heater tape is to be applied. Marking these locations will assist in proper placement of the heater tape. It is helpful to tape the templates to the back of the reflector to achieve proper spacing. Each dot on the template represents a point to be marked; punch through the paper at each dot location to penetrate the template so that the marker tip can touch the antenna surface.

4. Starting with one end of the heater tape, apply it to the back of the antenna by removing the adhesive liner strip as you progress. Press firmly on the tape for application to the antenna surface, smoothing out wrinkles in the tape as it is applied.

5. Carefully cut or tear the tape at the point a turn or bend is to be made. A knife may be required for this step. Use caution not to cut into the protective braid of the heater element. To dress out the ends of the heater tape, apply 2 pieces of aluminum tape (#18323) approximately 4-5" long in an "X" pattern (refer to Fig. 1). Finish the end by applying one more piece of tape 4-5" long perpendicular to the heater tape. This dressing is done for stress relief and tear resistance.

CAUTION: Use care in smoothing out the wrinkles. It is recommended that this process be done using fingers. Smoothing the wrinkles with objects (particularly, sharp or pointed objects) other than fingers increases the risk of tearing the top Aluminum lamination, which can expose the grounding braid on the internal heater wire along the ridge in the center of the tape. Exposure can keep the heater wire from making good contact with the antenna surface, reducing thermal transfer from the heater wire.

If a tear occurs and the grounding braid is exposed, the tear can easily be repaired. Cut a section of spare Aluminum tape (18323) the length of the tear, peel off the adhesive liner, and apply the Aluminum strip directly over the existing tape where the tear occurred.

INSTALLING THE FEEDHORN HEATER

6. Take the feedhorn heater band and put it around the scalar ring on the feedhorn (largest diameter). Pull the heater band tie wrap tight to secure the feedhorn heater. Run the feedhorn power supply cable into the power distribution junction box. Secure the cable to one of the feedhorn support arms with tie wraps spaced approximately 24" apart along the length of the support arm.

MOUNTING THE SENSOR AND CONTROL BOXES

The mounting bracket kits for the APS-4 box, distribution junction box, and the sensor box are designed to be a universal mount to fit a wide range of applications. The APS-4 box and the junction box brackets fit round king posts with an outer diameter from 2 inches up to 24 inches. For square king posts, the brackets fit a width of 1½ inches up to 18 inches. The bracket for the sensor box fits round feed arms with an outer diameter from ½ inch to ¾ inches, and square feed arms ¾ inch to 2¼ inch wide. It is possible that these brackets may work for other sizes/shapes of king posts and feed arms.

NOTE: The mounting brackets for the APS-4 box and the wiring junction box can only be mounted to the boxes one way. **The brackets should be mounted to the boxes with the supplied hardware *before* trying to mount them to the king posts.** If the brackets are mounted to the king post before being mounted to the boxes, they may bend and make it impossible to mount the boxes correctly. Before mounting the bracket to the box, make sure that the post clamp is in the approximate final position. When all the mounting hardware is tightened down to hold the box, it will also limit the movement of the clamp.

7. Refer to the APS-4 instruction manual for basic installation and operation. After mounting the all brackets to the APS-4 control unit (#17540), and power distribution junction box (#18685), they are ready to mount to the king post. The APS-4 box is mounted in the horizontal position (APS-4 label text horizontal). Mount the distribution junction box so the incoming power cord enters the top of the box. If this is not possible, then it should be mounted such that the fewest number of cords are coming out of the top.

8. The CIT-1 snow sensor junction box (#18688) mounts in a similar fashion; choose one of the locations suggested on page 1. The mounting kit is designed so that the box mounts to the big plate, the smaller plate mounts to the feed arm with pipe clamps, and the two plates are held together with the pivot screw; this will allow the sensor moisture cup to catch falling snow. The orientation of the sensor box and the mounting plate so that the pivot screw and the sensor are on the “top”. First, the sensor box should be mounted to its plate with the pivot screw still loose. Second, the whole assembly should be mounted to the feed arm so that the sensor points straight up. The pipe clamps should be tightened so that the assembly will not slide from the selected position. **Do not tighten the clamps too much and crush the arm.** Using the supplied tie wraps, secure the sensor cable along the support arm or along the reflector supports back to the junction box. Space the tie wraps approximately 24" apart. Refer to the CIT-1 instruction manual for basic installation and operation. Finally, select the final position for the sensor assembly, and tighten the pivot screw. At this point, all the hardware and clamps should be secure so that nothing will unintentionally move or fall.

9. Run the main power feed cable (#18724) from the APS-4 controller to the power distribution junction box.

10. Connect the heater power cables (#18684) to the heater tape as shown in Figure 2, and run the other ends into the power distribution junction box. Connect wires inside the junction box, following the appropriate wire color code (i.e., black to black, white to white, and green to green). Secure any excess power cables to the antenna pedestal using tie wraps.

11. Hook up incoming power to the APS-4 controller (240 VAC) using the power supply cable (#18724).

SYSTEM TEST AND CHECKOUT

12. To test and operate the system, first energize the power source. Begin the test by filling the moisture cup on the CIT-1 sensor with water. This will activate the moisture sensing circuit inside the control. Set the hold

on timer on the APS-4 control panel so that it is not on zero hours (an approximate 30 minute setting is sufficient for this test).

13. Next, use the Aerosol cooling spray to cool the ambient temperature sensor on the CIT-1 (a brown tube protruding from the bottom of the unit's housing). Do this for approximately 20 seconds to sufficiently cool the temperature sensor. This will give it time to react to the temperature change. When the ambient temperature is nominally above 38 deg. F, the CIT-1 sensor is in an idle state. Once the ambient temperature sensor detects temperature below the 38 deg. F setpoint, *and* moisture is present in the moisture cup, the sensor signals the APS-4 control panel to close it's internal contactor, energizing the heaters. After several minutes, the heater tape should become noticeably warmer to the touch. If either the ambient temperature sensor on the CIT-1 reaches 38 deg. F or above, or, moisture is no longer present in the moisture cup, the APS-4 control panel's hold-on timer will initiate a real-time count down cycle according to the timer's setting. The internal contactor will then remain closed (keeping the heaters energized) only for the duration of the hold-on cycle. Once the CIT-1 sensor detects ambient temperature above 38 deg. F, and/or moisture is absent from the moisture cup, there are several ways to halt this test before the hold-on cycle expires: 1) press the heater cycle button on the APS-4, 2) rotate the hold-on timer's knob counter-clockwise to zero hours, or 3) disconnect the power source at the load center or breaker box.

QUESTIONS AND COMMENTS

For technical help, questions or comments concerning this product or any of Environmental Technology, Inc. products contact the Customer Service Department between 8:00am and 5:00pm EST (UTC minus five hours) at

*Voice: 800.234.4239 (USA and Canada)
 219.233.1202 (elsewhere)
Fax: 888.234.4238 (USA and Canada)
 219.233.2152 (elsewhere)
E-mail: techsupport@networketi.com*

The ETI logo, Snow Switch, Floorstat, Tracon, We Provide Managed Heat, We Manage Heat are registered trademarks of Environmental Technology, Inc. 99+, ADH, APS, ARC Fault, CIT, DC Trace, Digital Anticipation, EDH, EUR, ES, FMC, FWT, GIT GPT, HSC, LCD, RCD, RCU, RMC, SIT and Snozone are Environmental Technology, Inc. trade Marks.
Copyright © 2000 Environmental Technology, Inc. All rights reserved.

All rights reserved. No part of this manual may be reproduced or translated in any form or by any means, electronic or mechanical including photocopying and recording, for any purpose without the express written consent of Environmental Technology, Inc.

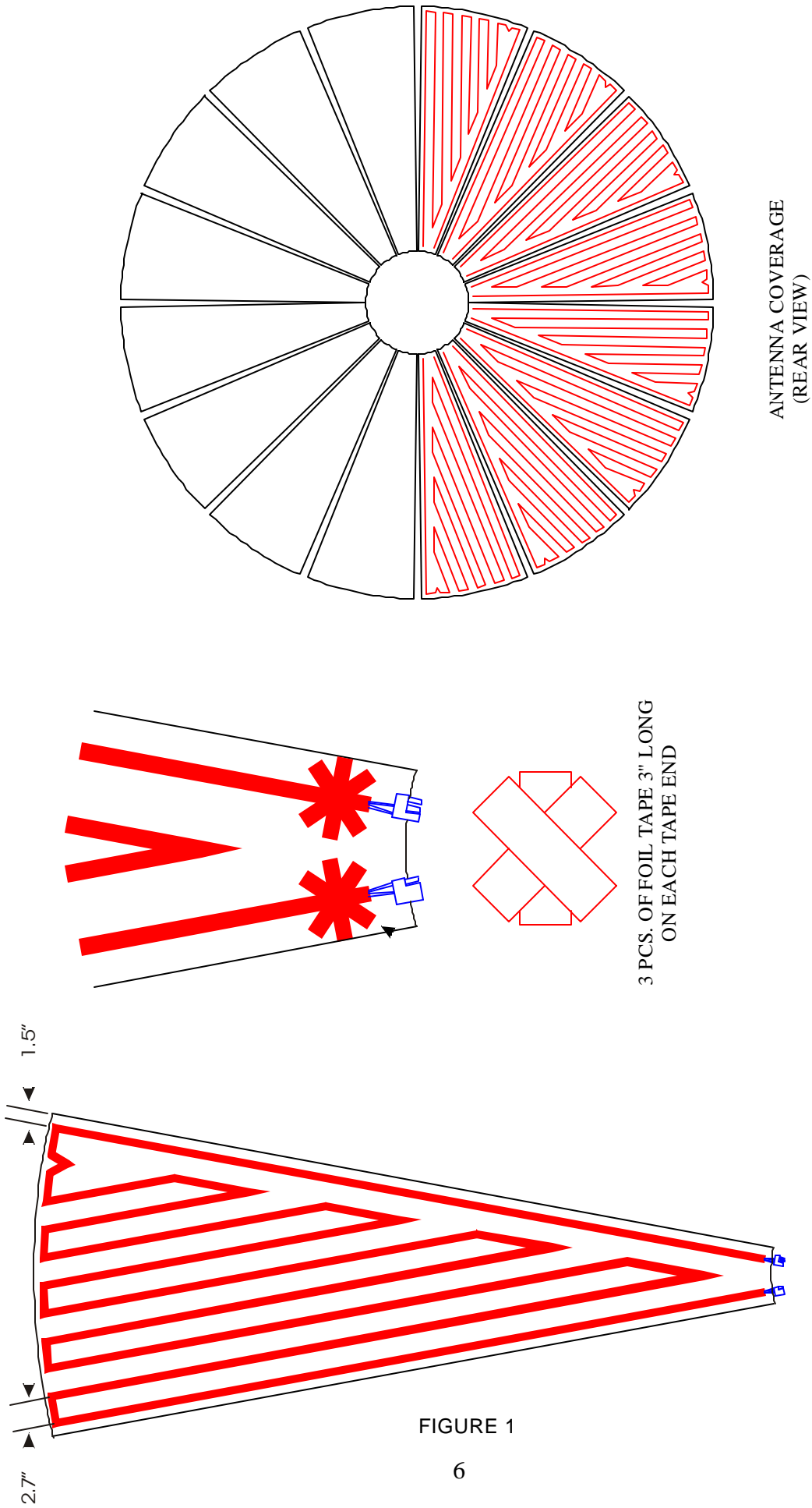

ANTENNA COVERAGE
(REAR VIEW)

3 PCS. OF FOIL TAPE 3" LONG
ON EACH TAPE END

SEGMENT PATTERN

FIGURE 1

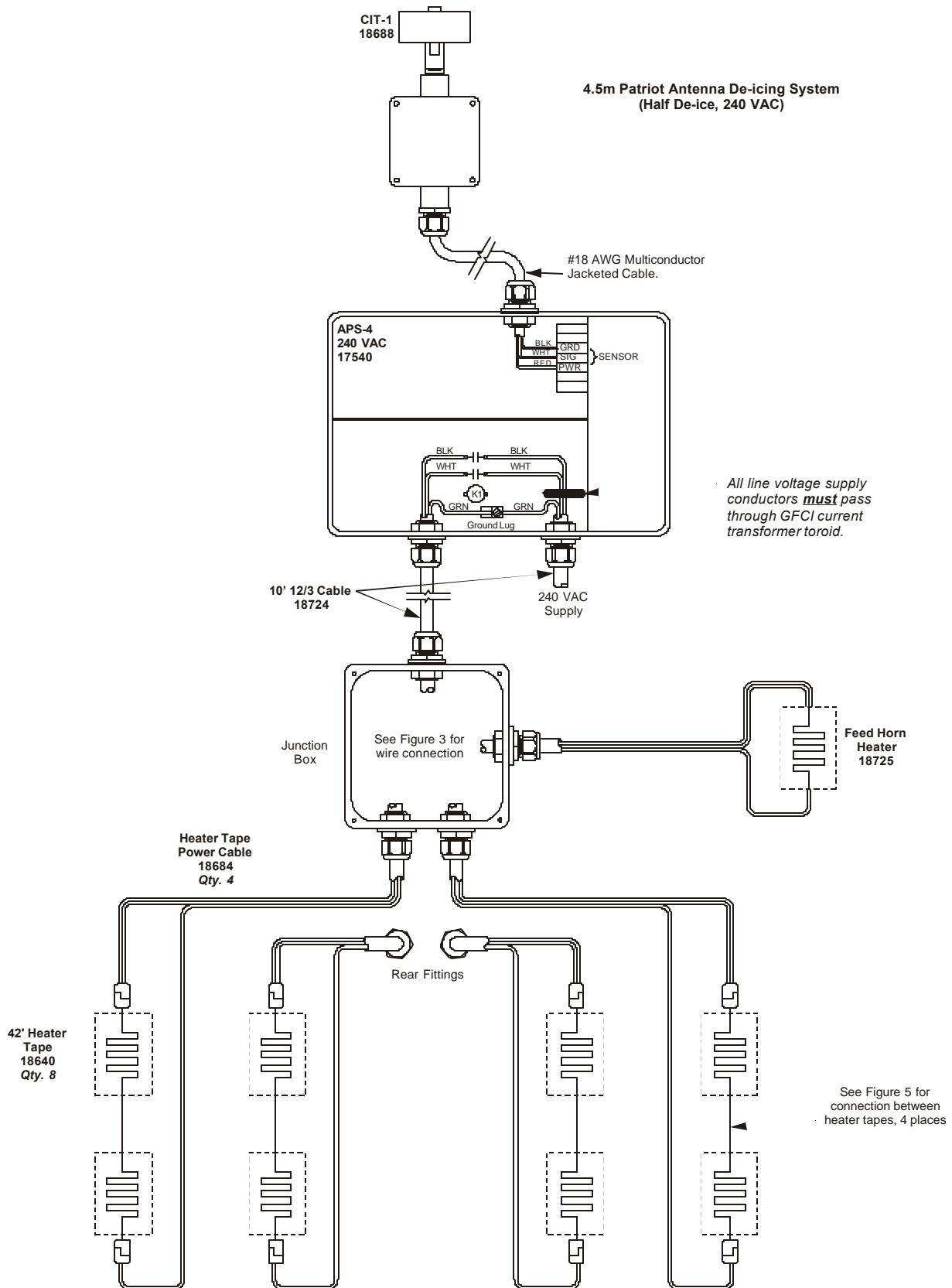

Figure 2
7

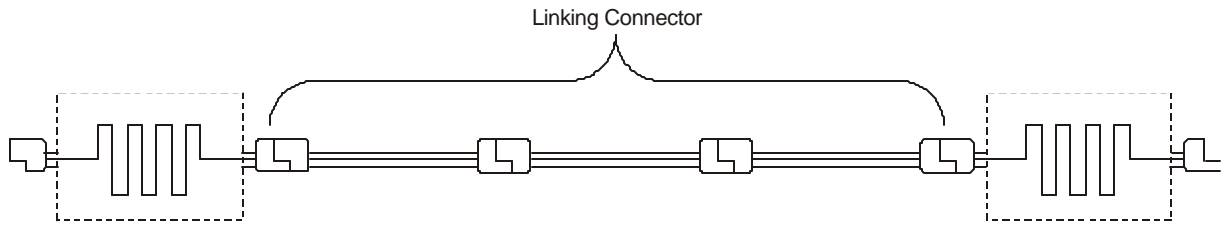

Figure 5

**4.5m Patriot Antenna De-icing System
(Half De-ice, 240 VAC)**

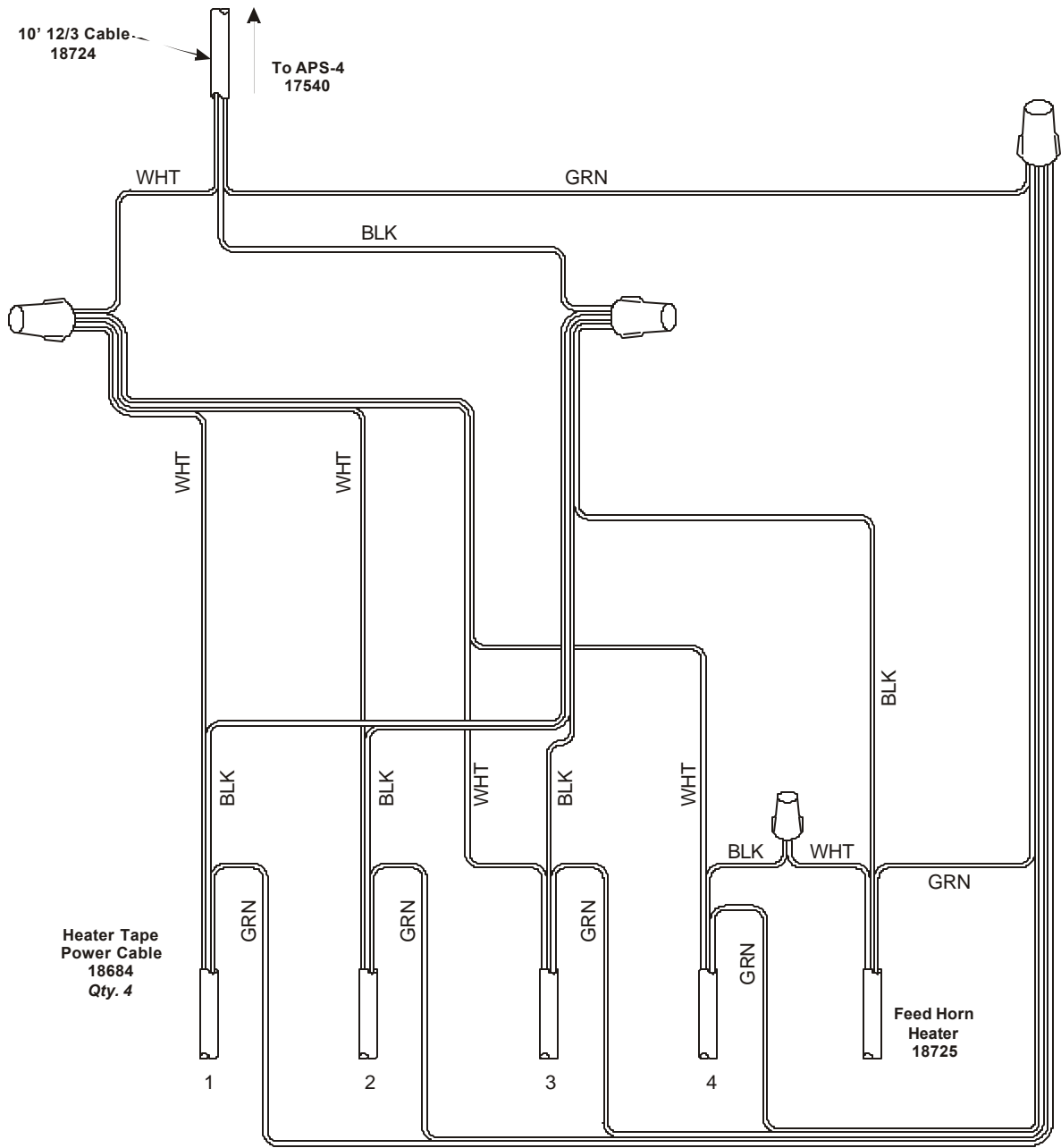
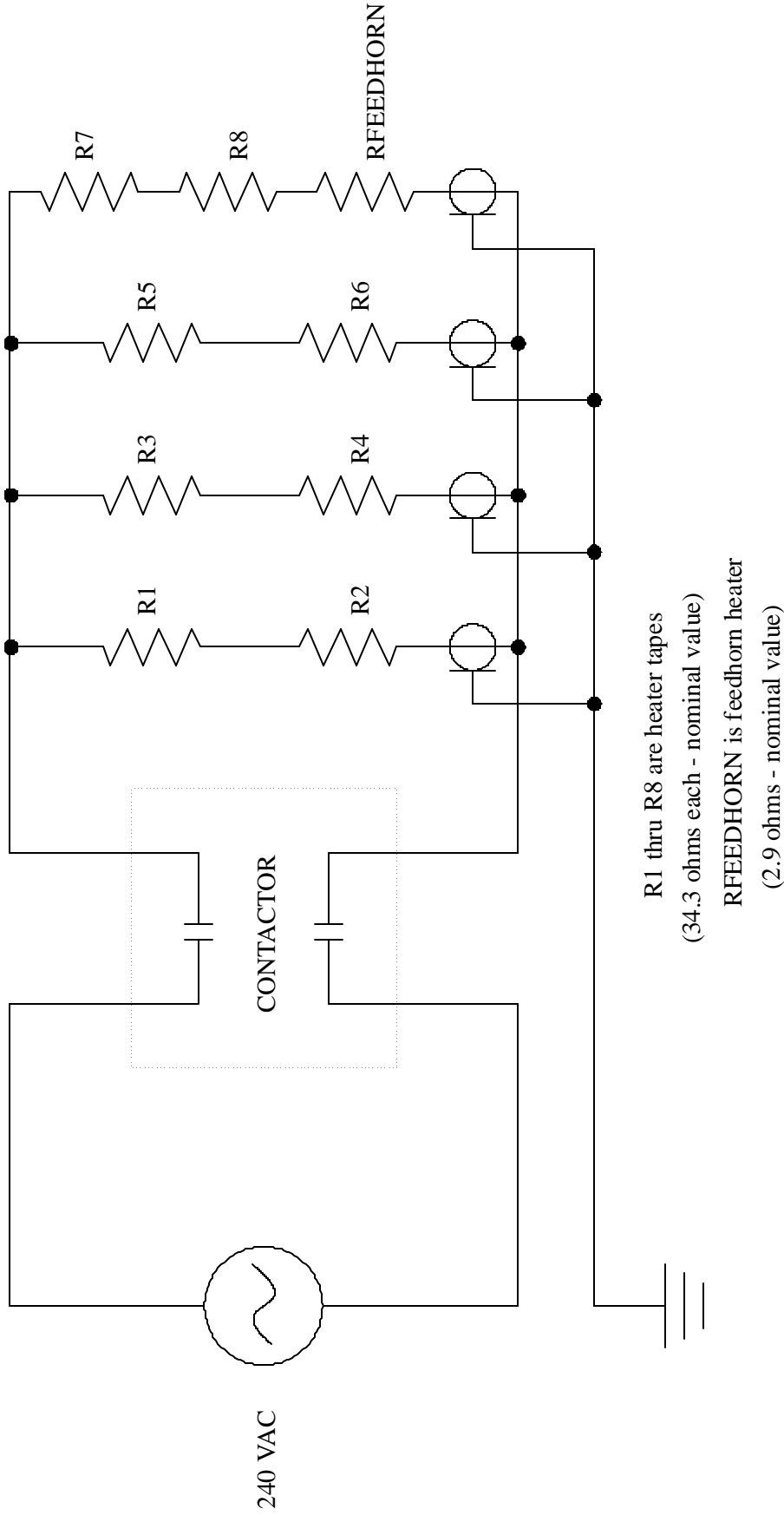

Figure 3
8

4.5m Patriot Antenna De-ice System
Electrical Schematic
(Half De-ice, 240VAC)



R1 thru R8 are heater tapes
(34.3 ohms each - nominal value)
RFEEDHORN is feedhorn heater
(2.9 ohms - nominal value)

Figure 4

TRADE SECRET - DO NOT COPY. THIS MATERIAL IS CONFIDENTIAL AND PROPRIETARY,
BEING EXCLUSIVELY OWNED BY ENVIRONMENTAL TECHNOLOGY INC., 1302 HIGH STREET,
SOUTH BEND, INDIANA 46801. THE EXPRESSION OF THE INFORMATION CONTAINED
HEREIN IS THE PROPERTY OF ENVIRONMENTAL TECHNOLOGY INC. AND ALL COPYING IS
PROHIBITED AND MAY BE SUBJECT TO CRIMINAL PENALTIES.

UNLESS OTHERWISE SPECIFIED:		DATE	3/23/98	ENVIRONMENTAL TECHNOLOGY INC. SOUTH BEND, INDIANA U.S.A.
THIRD ANGLE PROJECTION	DRW	J. MILLER	TITLE	
INCREASING DIMENSIONS	CHK			
3 PLACE DIM. +/-	APPD.			
2 PLACE DIM. +/-	PROVE DES			
ANGULAR DIM. +/-	PRCD.			
SCALE: NONE				FIG. NO. 10723

REVISIONS		DATE
SYM.	DESCRIPTION	