



We Manage Heat®

Freeze Protection Thermostats

MODELS SST-2

MANUAL

Part Number 22744

Installation and Operation Manual

Environmental Technology, Inc.

1850 N Sheridan Street
South Bend, Indiana 46628
(574) 233-1202 or (800) 234-4239
FAX (574) 233-2152 or (888) 234-4238
<http://www.networketi.com/>

Safety

Make all electrical connections in compliance with the National Electric Code (NFPA 70) and local electrical code. If you have questions concerning the installation or application, contact Customer Service.

Additional Information

More information is regularly made available through our website, www.networketi.com. Please visit us online for datasheets, manuals, white papers, technical articles and more. The most current and up to date version of this and every other manual for our products can be found in Acrobat (pdf) format to view online or to print. This is to assist you in installing and using our products to the best effect possible. If you have any comments about this or any other material from Environmental Technology please contact us.

Contacting Environmental Technology

For assistance, contact Customer Service. Office hours are 8:00 AM until 5:00 PM ET.

Voice: (800) 234.4239 (USA and Canada) or (574) 233.1202 (elsewhere)
 Fax: (888) 234.4238 (USA and Canada) or (574) 233.2152 (elsewhere)
 E-mail: helpdesk@networketi.com
 Mail: Environmental Technology, Inc.
 1850 North Sheridan Street
 South Bend, IN 46628

General

Description

The C-UL-US listed SST-2 Freeze Protection Thermostat replaces electromechanical thermostats in cost-sensitive applications requiring ground fault equipment protection (GFEP). The SST is classified to UL and CSA safety standards by UL for use in temperature-regulation applications. It is the ideal low-cost thermostat for areas not subject to mechanical abuse.

Specifications

General

| | |
|-------------|--|
| Area of use | Nonhazardous locations |
| Approvals |  Type 873 Temperature Regulating Equipment |

Enclosure

| | |
|------------------|---|
| Protection | NEMA 4x |
| Cover attachment | Polycarbonate cover, machine screws |
| Entries | 1 × 3/4" entry (bottom right) for NEC Class 2 sensor connections 3 × 1-1/16" entries (bottom left and left) for supply, load power and (right) NEC Class 2 alarm relay connections |
| Material | Polycarbonate |
| Mounting | Wall mounted |

Front Panel Interface

| | |
|------------------|---|
| Status indicator | SUPPLY (green) power applied SUPPLY (green, flashing) bad thermistor HEAT (yellow) call for heat GFEP (red) ground fault condition GFEP (red, flashing) failed GFEP test GFEP (red, flashing, rapid) GFEP test in progress |
|------------------|---|

Remote Interface

| | |
|----------------|---|
| Alarm relay | Isolated SPDT 1 AMP Class 2 contact |
| Summary alarms | No Power Ground Fault Condition GFEP function test failure Bad or missing Thermistor |

Control

| | |
|-----------------|---|
| Supply voltage | 120, 208, 240 or 277 volts, single phase (automatically selected) |
| Contact type | Two Form A DPST |
| Maximum Ratings | Voltage: 277 VAC Current: 30 amps |

Temperature Sensor

| | |
|--------------|--|
| Set point | 40°F (4.4°C) |
| Dead band | 2°F (1°C) |
| Sensor type | Thermistor network |
| Circuit type | NEC Class 2 |
| Lead Length | Up to 2,000' (610m) using 12 AWG 2-wire jacketed cable Up to 500' (152m) using 18 AWG 2-wire jacketed cable |

Ground Fault Equipment Protection (GFEP)

| | |
|---------------------|---|
| Set point | 30 mA |
| Automatic self test | Mode A: Verifies GFEP function before contactors operate Mode B: Verifies GFEP function every 24 hours |
| Manual test/reset | TEST/RESET switch on front panel |

Environmental

| | |
|-----------------------|--------------------------------|
| Operating temperature | -40°F to 130°F (-40°C to 55°C) |
| Storage temperature | -67°F to 167°F (-55°C to 75°C) |

Installation

Unpacking

Immediately inspect the packing material for damage. Unpack the SST-2, taking care not to damage the packaging material. Save the packaging material until normal operation has been established. If the unit must be returned, take care to ensure that it is repackaged as it was received.

Packing List

| | |
|-------|---|
| 22744 | SST-2 Freeze Protection Thermostat |
| 19272 | Temperature Sensor |
| 22804 | SST-2 Installation and Operation Manual |

Initial Inspection

Inspect the SST for shipping damage. If any of the following problems are found contact the Customer Service Department.

- Contents incomplete or incorrect
- Internal or external mechanical damage

Customer service is available between 8:00 a.m. and 5:00 p.m. ET at (574) 233-1202 or (800) 234-4239. In the event of shipping damage, keep the packing materials for inspection by the carrier. Normally, Environmental Technology, Inc. will repair or replace the SST without waiting for the claims settlement.

Location

Housed in a NEMA 4X rated enclosure, the SST freeze protection thermostat can be mounted in either indoor or outdoor environments. The SST was designed to operate over an ambient temperature range of -40° to 136°F (-40° to 58°C).

Using the integral mounting flanges, the SST is intended to be installed on a fixed, flat, vertical surface. The mounting flanges accommodate $1/4$ " (6mm) fasteners.

The SST freeze protection thermostat nonmetallic enclosure is furnished with two $3/4$ " (21mm) conduit entries. The lower conduit entries provide for line voltage supply branch circuit conductors. The conduit entry at the top-left of the enclosure is for heater load branch circuit conductors. The installed weather-tight fitting is for the low voltage, NEC Class 2, temperature sensor. The Temperature Sensor may be located up to 2,000' (610m) from the SST.

Supply Voltage

The SST freeze protection thermostat operates from 120, 208, 240 or 277 VAC at 50/60 Hz. For line supply and load connections, use 10 AWG or larger wires rated for at least 75°C (167°F) at 300 VAC.

Contactors Ratings

The heater contactor provides two (2) Form A (DPST) definite purpose contacts rated for up to 30 amp AC heater loads at voltages at or below 277 VAC.

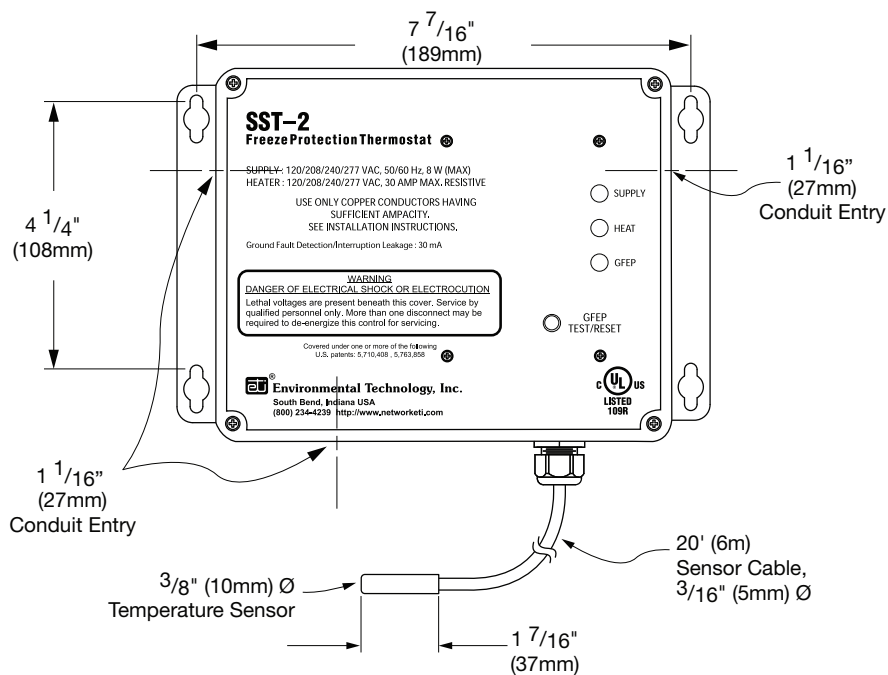

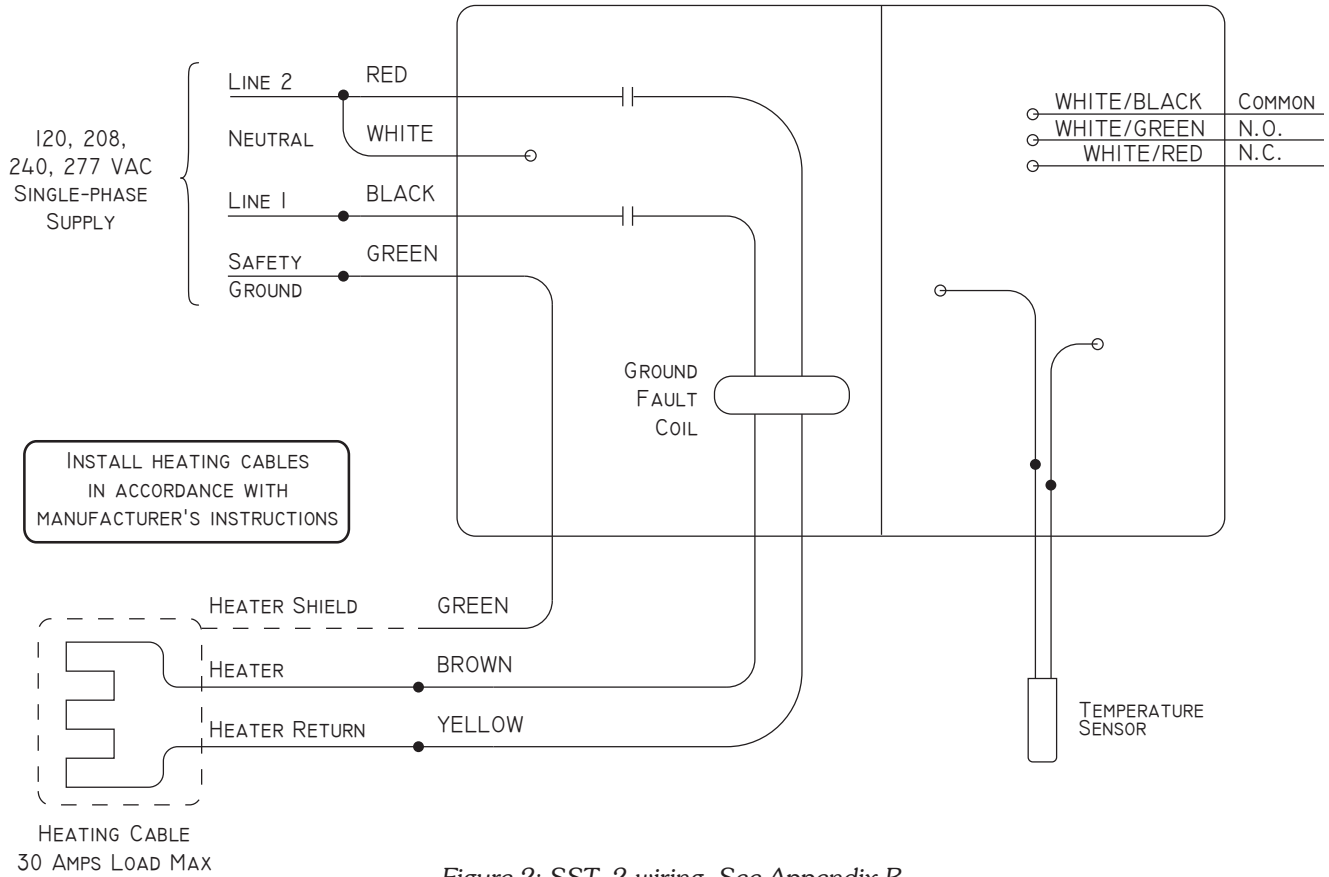

Figure 2: SST-2 wiring. See Appendix B.

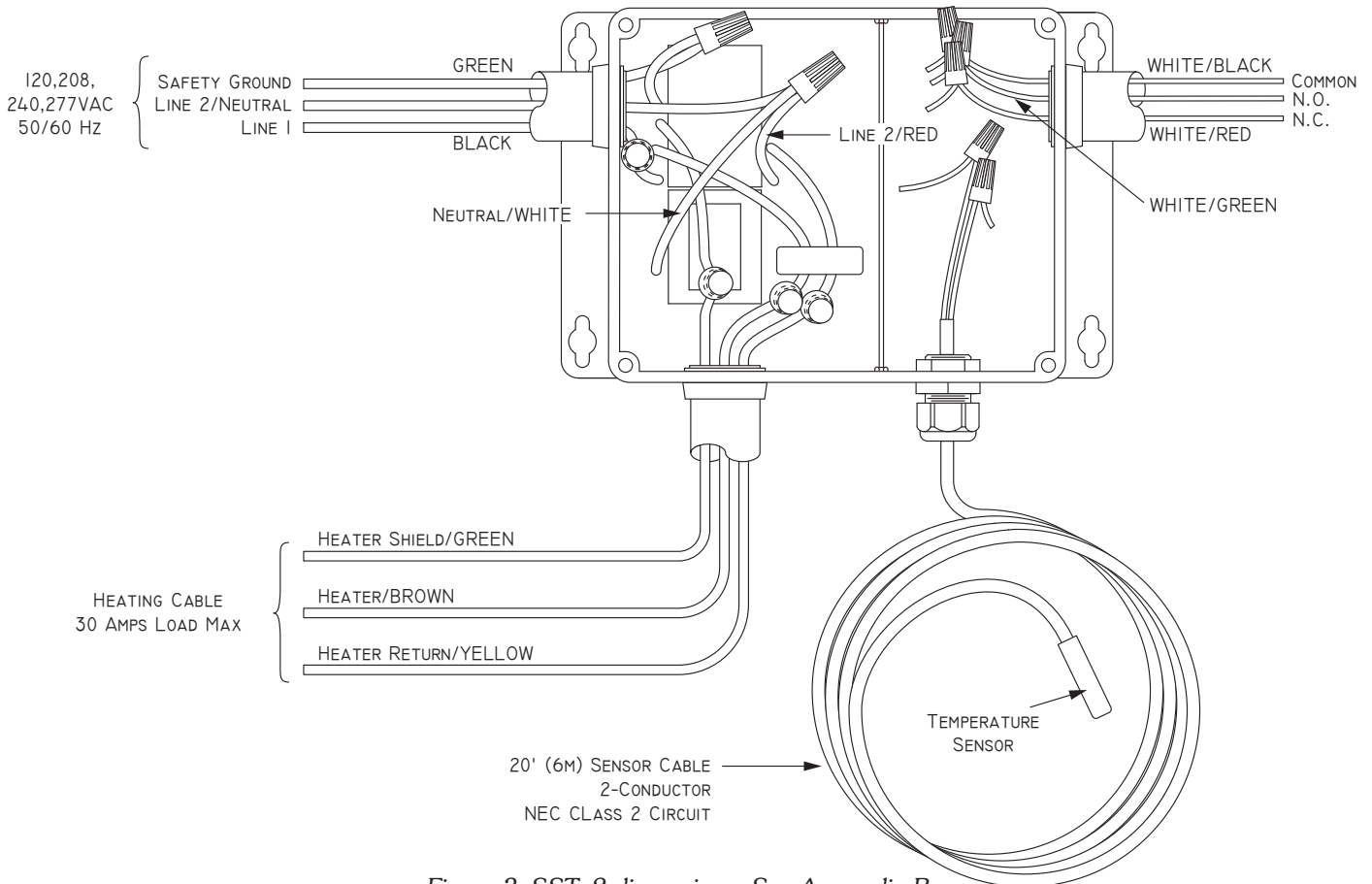

Figure 3: SST-2 dimensions. See Appendix B.

NEC Class 2 Low Voltage Connections

All low voltage wiring shall use 18 AWG or greater stranded conductors with thermoplastic insulation rated for at least 75°C (194°F) at 300 VAC. The temperature sensor is supplied with a 20' (6m) 2-wire jacketed cable lead. The temperature sensor lead may be up to 500' (152.4m) using 18 AWG 2-wire jacketed cable, or up to 2,000' (609.6m) using 12 AWG 2-wire jacketed cable.

Temperature Sensor

The Temperature Sensor is required for the operation of the SST. The Temperature Sensor connects via wire nuts to the two blue wires in the SST enclosure. It does not matter which sensor wire is connected to which blue wire in the enclosure. The sensor should be located near the heater being controlled and is used to monitor its temperature.

Operating Instructions

Power On Startup Test

When power is applied to the SST-2 freeze protection thermostat, the LED indicator lights in the SST enclosure will cycle for two seconds and then turn off, except for the green SUPPLY indicator, which will remain lit whenever the SST senses supply power.

Next, the SST-2 freeze protection thermostat performs a self-test of the ground fault circuitry. This is the same test automatically performed approximately every 24 hours. Failure of the ground fault circuitry self-test will disable the SST; call Customer Service.

Operation

The SST-2 freeze protection thermostat does not require user attention during normal operation.

| | |
|------------------|---|
| Status indicator | SUPPLY (green) power applied SUPPLY (green, flashing) bad thermistor HEAT (yellow) call for heat GFEP (red) ground fault condition GFEP (red, flashing) failed GFEP test GFEP (red, flashing, rapid) GFEP test in progress |
|------------------|---|

GFEP Test

To manually verify the operation of the ground fault circuitry, momentarily press the GFEP TEST/RESET switch on the SST. This should not normally be necessary as the SST will test the ground fault circuitry when power is applied to the unit and once approximately every 24 hours as long as power is supplied to the unit.

GFEP Reset

In the event that a ground fault condition is detected by the SST heaters will be turned off, if on, and heaters will be prevented from further operation until the ground fault condition has been reset. The red GFEP Fault indicator will be continuously on as long as there is power to the SST and a ground fault condition

remains. The ground fault condition will be persistent and will be remembered by the SST even if the unit loses power.

To clear the ground fault condition momentarily press the GFEP TEST/RESET switch on the SST.

Maintenance

The SST-2 does not require routine maintenance.

For technical help, questions or comments concerning this product or any Environmental Technology, Inc. products contact the Customer Service Department between 8:00am and 5:00pm ET at:

Voice: 800.234.4239 (USA and Canada) or 574.233.1202 (elsewhere)
Fax: 888.234.4238 (USA and Canada) or 574.233.2152 (elsewhere)
E-mail: helpdesk@networketi.com

Appendix A. SST-2 Dimensions.

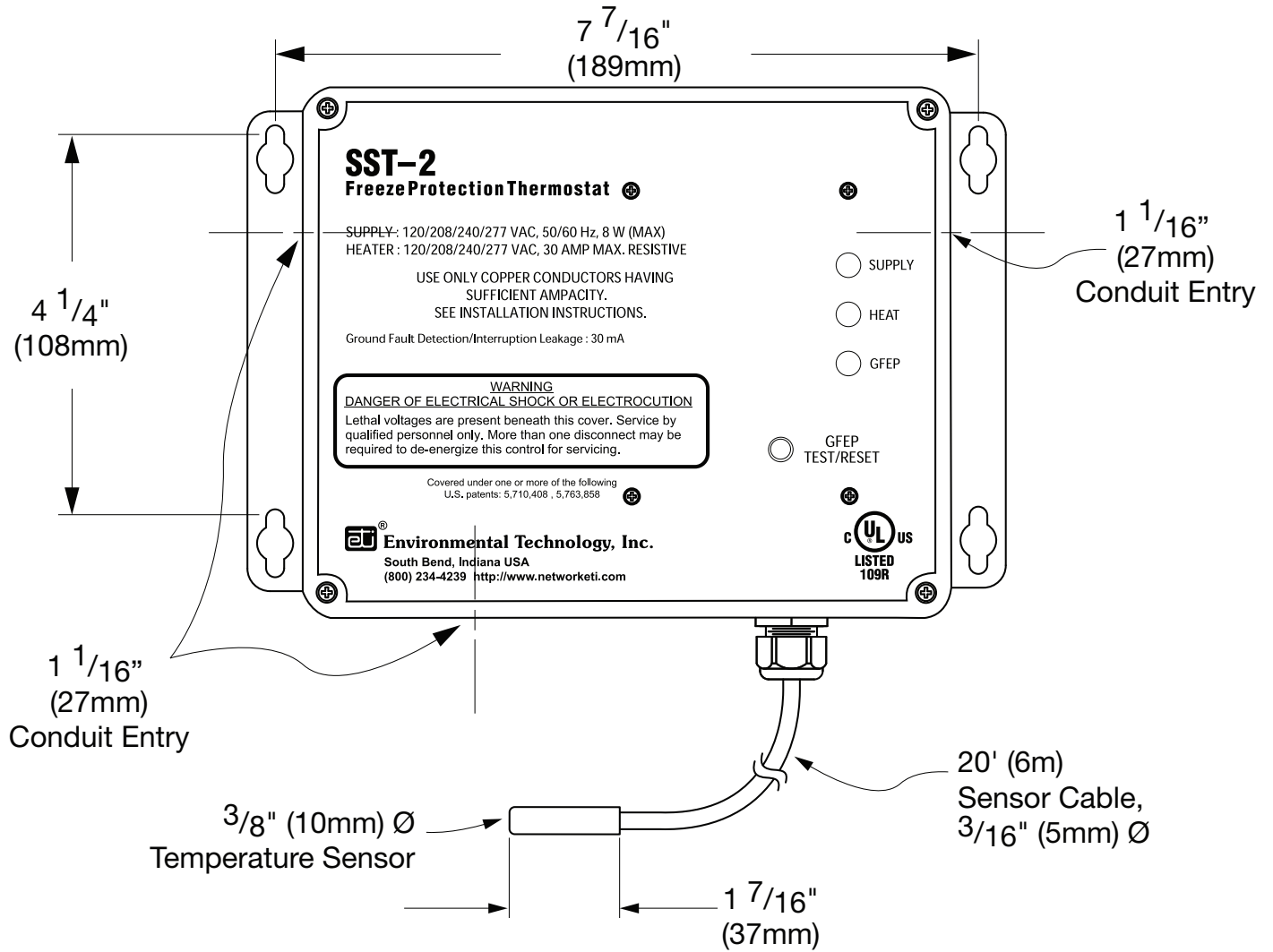

Appendix B. SST-2 Wiring Diagram.

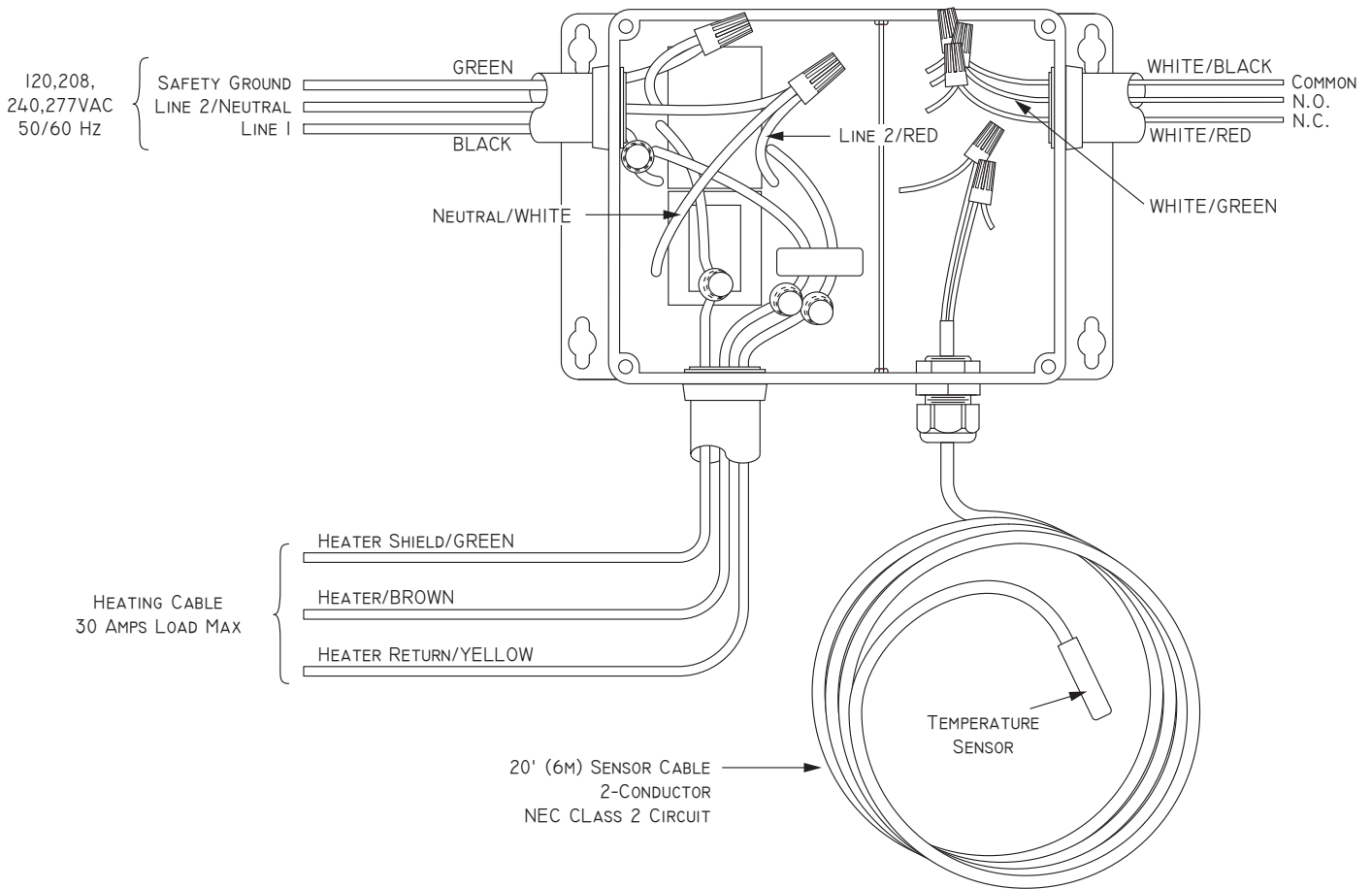

Appendix C. SST-2 Wiring.

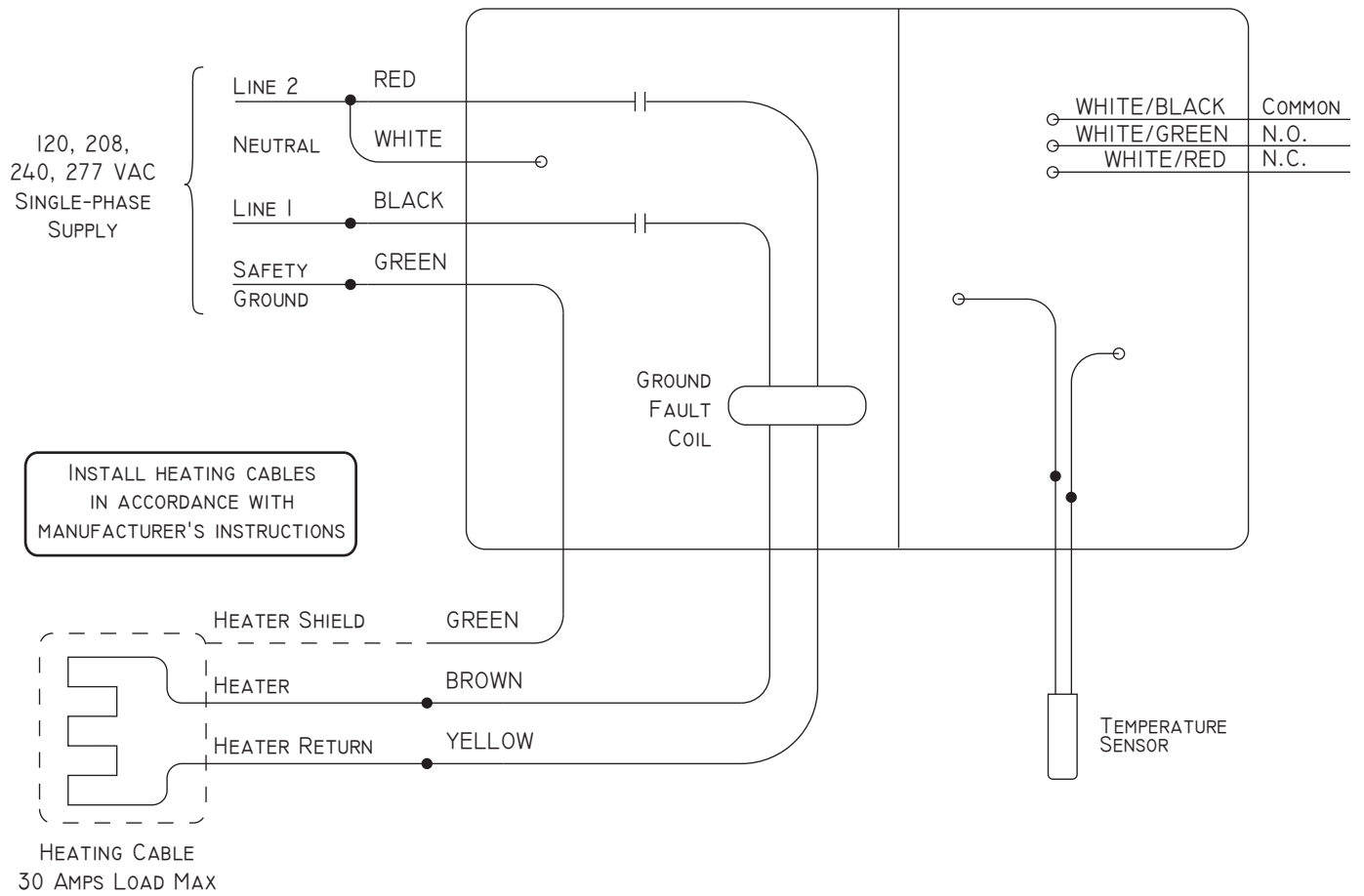

ORDERING INFORMATION

| Order Number | Description |
|--------------|--|
| 22744 | Model SST-2 Freeze Protection Thermostat |
| 19272 | Temperature Sensor (included) |

LIMITED WARRANTY

ETI's two year limited warranty covering defects in workmanship and materials applies. Contact Customer Service for complete warranty information.

DISCLAIMER

Environmental Technology, Inc. makes no representations or warranties, either expressed or implied, with respect to the contents of this publication or the products that it describes, and **specifically disclaims any implied warranties of merchantability or fitness for any particular purpose**. Environmental Technology, Inc. reserves the right to revise this publication, and to make changes and improvements to the products described in this publication, without the obligation of Environmental Technology, Inc. to notify any person or organization of such revisions, changes or improvements.