



Automatic Snow/Ice Melting System Control Panel  
**MODEL APS<sup>®</sup>-3C SNOW SWITCH<sup>®</sup>**

Automatic Snow/Ice Melting System Control Panel  
**MODEL APS<sup>®</sup>-4C SNOW SWITCH<sup>®</sup>**

Modular Snow/Ice Heater Control System  
**MODEL SC<sup>™</sup>-40C SATELLITE CONTACTOR**

MANUAL

---

## Installation and Operation Manual

### **Environmental Technology, Inc.**

1850 N Sheridan Street  
South Bend, Indiana 46628  
(574) 233-1202 or (800) 234-4239  
FAX (574) 233-2152 or (888) 234-4238  
<http://www.networketi.com/>



## Safety

Make all electrical connections in compliance with the National Electric Code (NFPA 70) and local electrical code. If you have questions concerning the installation or application, contact Customer Service.

## Additional Information

More information is regularly made available through our website, [www.networketi.com](http://www.networketi.com). Please visit us online for datasheets, manuals, white papers, technical articles and more. The most current and up to date version of this and every other manual for our products can be found in Acrobat (pdf) format to view online or to print. This is to assist you in installing and using our products to the best effect possible. If you have any comments about this or any other material from Environmental Technology please contact us.

## Contacting Environmental Technology

For assistance, contact Customer Service. Office hours are 8:00 AM until 5:00 PM ET.

Voice: (800) 234.4239 (USA and Canada) or (574) 233.1202 (elsewhere)  
 Fax: (888) 234.4238 (USA and Canada) or (574) 233.2152 (elsewhere)  
 E-mail: [helpdesk@networketi.com](mailto:helpdesk@networketi.com)  
 Mail: Environmental Technology, Inc.  
 1850 North Sheridan Street  
 South Bend, IN 46628

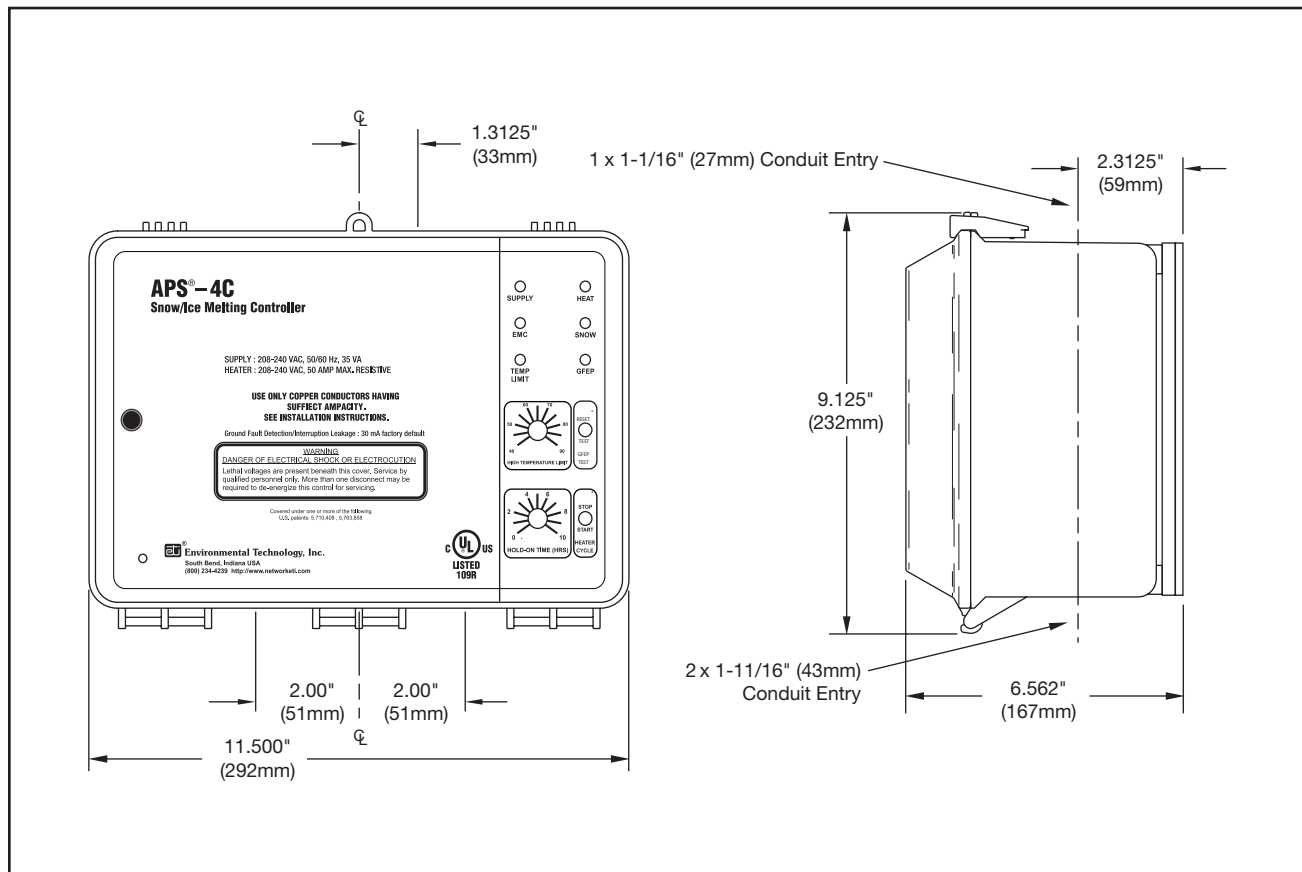

Figure 1: APS-4C dimensional

## General

### Introduction

The APS "C" Series Snow Switch Control Panels, when used with compatible sensors, automatically controls snow and ice melting systems, ensuring complete snow and ice melting at minimum operating costs. Typical applications include pavement, sidewalk, loading dock, roof, gutter and down spout snow/ice melting.

The APS "C" Series continues the APS family of control panels with the APS-3C Control Panel, the APS-4C Control Panel and the SC-40C Satellite Contactor. All three models improve on and extend the features of previous models while maintaining backwards compatibility. The new APS "C" Series models are interchangeable with earlier APS models to ensure the continued long life of existing systems.

The APS "C" Series offers voltage options from 120 VAC up to 600 VAC. The APS-3C is available for 120 and 208-240 VAC and is optimized for inductive loads up to 24 amps, ideal for use in hydronic systems or with customer systems that provide a relay interface. The APS-4C and the SC-40C are available for 208 VAC through 600VAC and are optimized for resistive loads up to 50 amps, with integrated ground fault equipment protection (GFEP).

All of the APS "C" Series models provide a relay closure interface for use with energy management computers (EMC). This feature can also be used for general purpose remote control and annunciation and other advanced applications. Simple remote control features are also provided by the RCU-3 Remote Control for the APS-3C and the RCU-4 Remote Control for the APS-4C and SC-40C.

All sensor and communications wiring is NEC Class 2. This simplifies installation while enhancing fire and shock safety. The APS-3C and APS-4C can interface up to six sensors from the CIT-1 product family. More sensors provide superior performance by better matching the controller to site performance requirements. (The SC-40C does not make use of snow/ice sensors but rather is notified of snow conditions by the master APS in the system.)

### Environmental Interfaces

The APS "C" Series determines when to start heater operation by monitoring the signals produced by up to six customer supplied environmental sensors paralleled together using a three-wire bus. Available sensors include:

- SIT-6E Pavement Mounted Snow and Ice Sensor
- CIT-1 Aerial Snow and Ice Sensor
- GIT-1 Gutter Snow and Ice Sensor

When used either alone or in combination, these sensors accurately determine whether or not snow and ice melting is required. This data is communicated back to either an APS-3C or APS-4C control.

Sensors measure ambient temperature and detect moisture, in any form. Snow, sleet, freezing rain, etc. is assumed if moisture is present at temperatures below 38°F (3.33°C). Beginning heater operation at temperatures slightly above freezing is essential to meeting customer expectations. It takes a long time for snow to melt at 34°F.

Using several sensors improves snow melting effectiveness by compensating for environmental variations. Consider a typical pavement snow and ice melting system. Vehicular and pedestrian traffic in commercial environments often expose the pavement to tracked slush and blowing or drifting snow. Since re-freezing could create a hazardous situation, these hazards must be cleared. The solution is to combine several SIT-6E pavement sensors in expected pedestrian and vehicular pathways and a CIT-1 placed high in an open, unobstructed location where it is exposed to falling snow. One or more additional SIT-6E pavement sensors may need to be used in areas subject to drifting and blowing snow and/or melt water run off

and refreezing.

The first sensor detecting freezing precipitation calls for snow melting. The last sensor clearing of frozen precipitation signals the APS Control Panel that heating is no longer required.

Sensors employ a heated interdigitated grid for moisture detection. Heat melts frozen precipitation to form water which is a better conductor of electricity. Circuits detect water as a change in resistance between the fingers of the interdigitated grid. The temperature of the moisture sensor is regulated electronically.

Each sensor has its own microcontroller for signal processing, logic and control. This enables the use of a simple 3-wire bus to connect sensors with the control. Extension wire function and colors follow:

- Supply (Red)
- Signal (White)
- Ground (Black)

The supply voltage is nominally 24 VAC. The signal is inverted. That is, snow produces a ground and its absence produces 24 VAC rectified.

Sensors are wired together in parallel in a “wired OR” configuration. That is, red to red, white to white and black to black. When several sensors are connected in parallel, any sensor asserting a ground on the signal conductor enables snow melting heater operation. No ground on the signal line indicates the absence of snow.

APS “C” series models include a temperature sensor for measuring pavement slab or ambient air temperature. Its signal is used to provide an adjustable high limit thermostat function. This feature is essential when using a potentially high temperature heater such as MI cable.

## High Limit Thermostat

The calibrated 40°F to 90°F (4°C to 32°C) high limit thermostat prevents excessive temperatures when using constant wattage and MI heaters. It also permits safe testing at outdoor temperatures too high for continuous heater operation. The temperature sensor is included.

There are two DIP switch configurable operation modes for the high limit thermostat. The factory default operation mode uses the high limit thermostat as a slab temperature regulator, preventing heater operation at temperatures above the set HIGH TEMPERATURE LIMIT. The optional operation mode uses the high limit thermostat as an ambient air sensor, preventing heater operation at temperatures above the set HIGH TEMPERATURE LIMIT until the temperature comes back within limits.

The details of operation in each mode are as follows:

### Slab Regulating Thermostat Mode

- High temperature causes unit to turn off heaters, if running, and to ignore any call for heater operation from the panel, RCU or EMC.
- High temperature continues any hold-on cycle that was initiated before the high temperature condition. If the slab temperature drops within limits during the hold-on time the heater will be turned back on.
  - In a high temperature condition an APS will still initiate operation of connected SC-40C contactor(s).
  - The HEATER CYCLE functions normally.

### Ambient Temperature Thermostat Mode

- High temperature causes unit to turn off heaters, if running, and to ignore any call for heater operation from the panel, RCU or EMC.
- High temperature cancels any hold-on cycle that was initiated before the high temperature condition.

- In a high temperature condition an APS will not initiate operation of connected SC-40C contactor(s).
- If the HEATER CYCLE switch is operated in a high temperature condition the heater(s) will be turned on for a maximum of 30 seconds. A new HEATER CYCLE can not be initiated for another two minutes after that.

## Hold-on Time

The adjustable hold-on timer provides three functions affecting heater operation. The hold-on timer is used to continue heater operation, to manually operate heaters or to provide a limited heater cycle for testing.

During normal operation the hold-on timer continues heater operation for an adjustable time period of up to 10 hours after snow stops. The additional operating time compensates for the fact that there may be insufficient power to both melt the snow as it falls and evaporate the resultant melt water.

After normal operation has ended the hold-on timer provides a method for clearing tracked or drifting snow that did not fall on a sensor. This can be accomplished by either increasing the hold-on or by manually toggling the heaters on for the hold-on time independent of environmental conditions.

Lastly, the hold-on timer provides a method of safe heater testing that is independent of environmental conditions. The High Limit Thermostat ensures that this is the case. In ambient mode, at ambient temperatures above the high limit, the manual hold-on time is reduced to 30 seconds. In pavement mode, at pavement temperatures above the high limit, heaters are disabled.

## Initial Settings

When first placing the system in service, the hold-on time should be set to an initial value. Three to five hours is suggested as a starting point. If the heaters turn off before the snow is completely cleared and the melt water evaporated, increase the hold-on time by an hour or two. If the heaters operate for several hours after the pavement is clear and dry, decrease the hold-on time by an hour. Continue this process until satisfactory performance is achieved.

**The small amount of energy wasted by a slightly excessive hold-on time is secondary to complete snow clearing and melt water evaporation. Incomplete operation is not desirable since this can result in re-freezing melt water which creates a slippery ice film.**

## If The System Turns Off Too Soon

If the system turns off before the pavement is clear and dry, toggle the heaters on for the hold-on using the HOLD-ON switch on the front panel of the control. Repeat as many times as is necessary until the pavement is clear and dry. If the heaters remain operating after the pavement is clear and dry, terminate the hold-on cycle with the HOLD-ON switch. Normal operation resumes if it starts snowing during hold-on.

## Ground Fault Equipment Protection (GFEP) Operation

GFEP operates in the event of a deicing heater failure indicated by excessive leakage current to ground. The leakage current equals the difference between the line and return currents flowing through the heaters. A precision current transformer measures the difference in currents. If the difference exceeds 30 mA, the heater contactor drops out. This removes heater power, thus eliminating potential fire and electric shock hazards.

Sometimes longer length and/or higher voltage heaters cause nuisance GFEP operation. This is true even though the heaters are operating properly. Increasing

the GFEP operating current can correct this problem. A DIP switch can increase the operating current from a default value of 30 to 60 or 120 mA.

Restoring heater operation requires operating the RESET switch on the front panel of the control. This starts a sequence of events beginning with testing the GFEP to make certain that it operates properly. If it is inoperative, the GFEP condition persists. Otherwise, the heater contactor is energized. If excessive ground current flows, the GFEP drops the contactor and waits for operation of the RESET switch. Otherwise, the contactor is operated only if there is a call for heat.

The GFEP checks itself and the deicing heaters every 24 hours independent of environmental conditions. Operating the TEST switch on the front panel performs the same function. In addition, the GFEP function is tested each time the heater control contactor operates.

## Energy Management Computer (EMC) Interface

The APS "C" Series interfaces an EMC via relays. Inputs from the EMC include OVERRIDE ON which causes heater operation and OVERRIDE OFF which inhibits heater operation. These functions are independent of weather conditions and the status of the hold-on timer. The interface provides five system status contact closures for the EMC including SUPPLY, SNOW, HEATER, ALARM and TEMPERATURE LIMIT.

Absent signals from the EMC, the APS control panel controls the heaters based on environmental conditions. Automatic snow melting control is the default condition of the system.

## APS-3C Front Panel

The APS-3C has indicators, adjustments and a switch for local control of the snow melting system. Indicators include LED lights for SUPPLY, SNOW, HEAT, EMC, TEMP LIMIT and GFEP. Adjustments provided allow for the calibrated adjustment of system HOLD-ON time from zero to ten hours (or off) and TEMP LIMIT for the high-

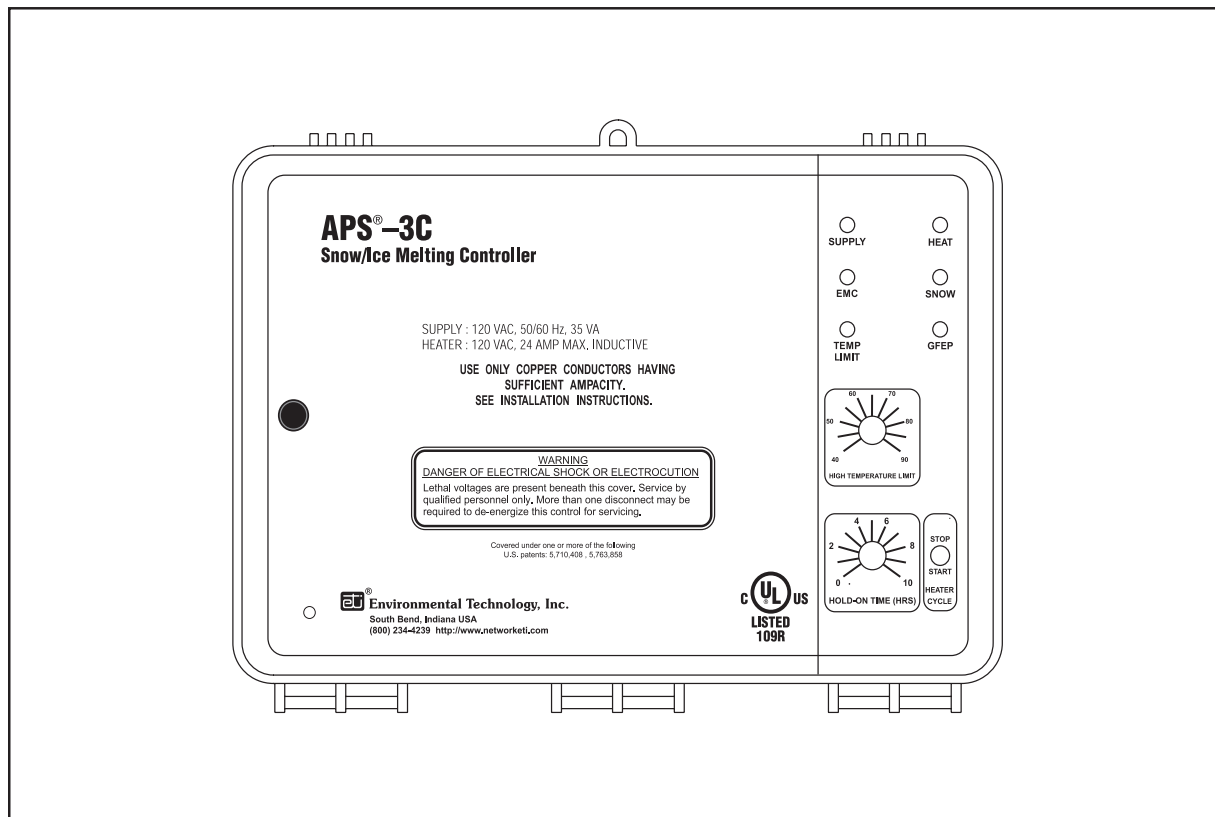

Figure 2: APS-3C front panel detail

limit temperature adjustment with a range of 40° to 90°F (4° to 32°C). The HEATER TOGGLE switch allows for the starting and stopping of a manual HEATER CYCLE.

Figure 2 shows the APS-3C front panel layout.

### APS-4C Front Panel

The APS-4C has indicators, adjustments and a switch for local control of the snow melting system. Indicators include LED lights for SUPPLY, SNOW, HEAT, EMC, TEMP LIMIT and GFEP. Adjustments provided allow for the calibrated adjustment of system HOLD-ON time from zero to ten hours (or off) and TEMP LIMIT for the high-limit temperature adjustment with a range of 40° to 90°F (4° to 32°C). There are two toggle switches. The GFEP TEST toggle switch toggles up to RESET a ground fault condition and toggles down to TEST the ground fault circuitry. The HEATER TOGGLE switch allows for the starting and stopping of a manual HEATER CYCLE.

Figure 3 shows the APS-4C front panel layout.

### SC-40C Front Panel

The SC-40C has indicators, adjustments and a switch for local control of the snow melting system. Indicators include LED lights for SUPPLY, SNOW, HEAT, EMC, TEMP LIMIT and GFEP. Adjustments provided allow for the calibrated adjustment of system HOLD-ON time from zero to ten hours (or off) and TEMP LIMIT for the high-limit temperature adjustment with a range of 40° to 90°F (4° to 32°C). There are two toggle switches. The GFEP TEST toggle switch toggles up to RESET a ground fault condition and toggles down to TEST the ground fault circuitry. The HEATER TOGGLE switch allows for the starting and stopping of a manual HEATER CYCLE.

Figure 4 shows the SC-40C front panel layout.

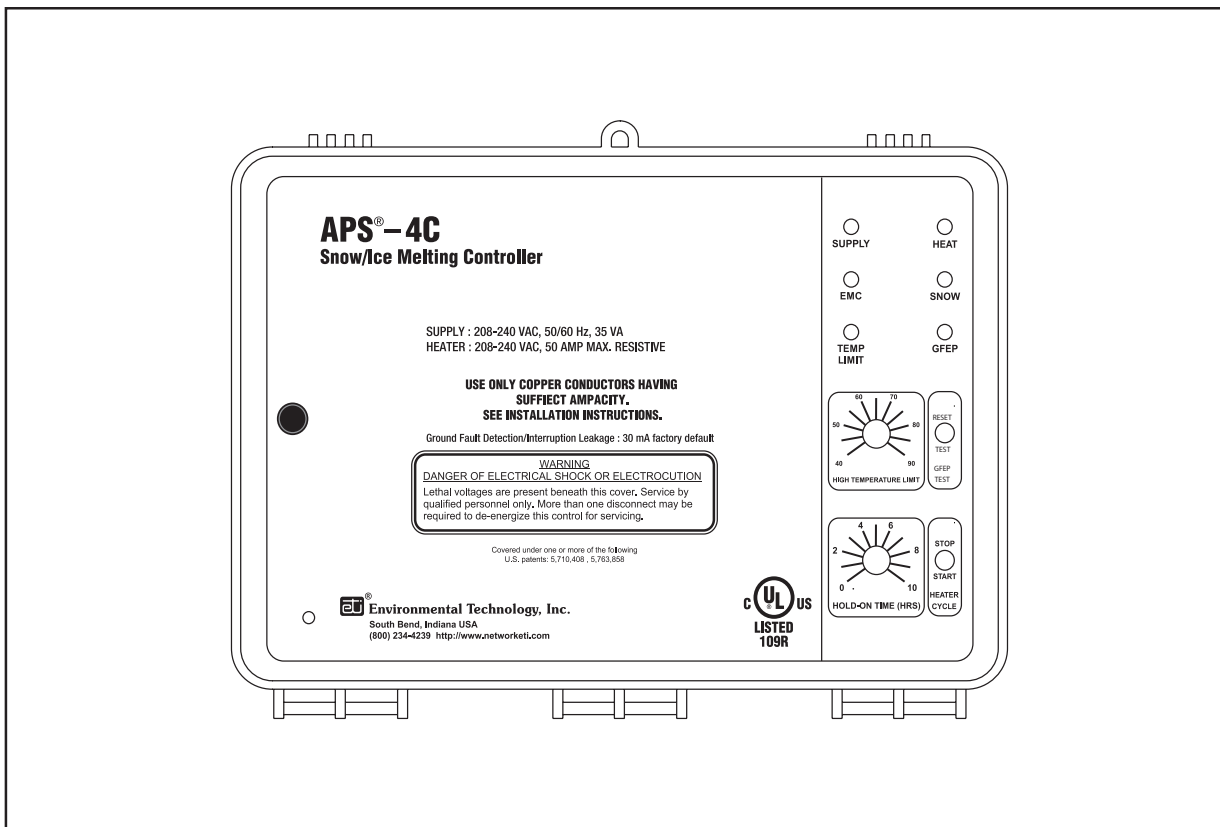

Figure 3: APS-4C front panel detail



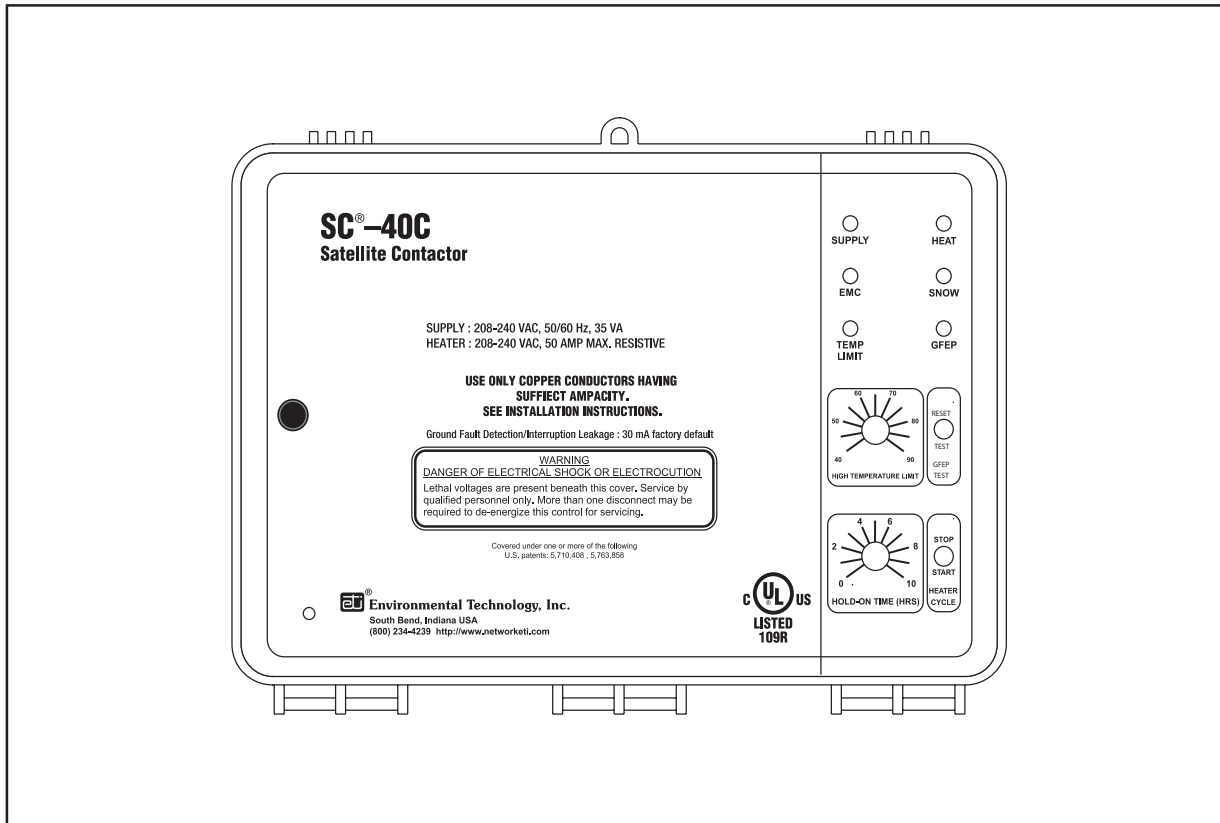

Figure 4: SC-40C front panel detail

## RCU-3 Remote Control Unit

The RCU-3 Remote Control Unit is used with the APS-3C. It adds remote control and status display to the APS-3C control at a location convenient to personnel capable of observing snow melting system operation.

Snow, slush or ice, either alone or in combination, must contact at least one sensor to start melting. Heater operation continues until all sensors are dry. Depending up the rate of fall, snow density, wind velocity, power density and other factors, heater operation must continue for a period of time after the last sensor dries off. Slush tracked by vehicle and pedestrian traffic along with blowing and drifting snow are problems that are hard to predict.

The cycle timer in the APS-3C begins when the last sensor dries off and continues for an adjustable period of up to 10 hours to keep the heaters operational until the pavement is completely dry. Otherwise, residual water could re-freeze and create a hazardous condition.

The RCU-3 provides a two, four, six or eight hour CYCLE TIME adjustment that is independent of the cycle time in the APS-3C. This allows treatment of the condition requiring an additional heater cycle as the exception rather than the rule in order to minimize energy use.

Operating the HEATER CYCLE switch operates heaters for the CYCLE TIME which is normally set to 2 hours. Operating the HEATER CYCLE switch during the cycle time stops the timer. If the pavement or ambient temperature exceeds the APS-3C HIGH LIMIT TEMPERATURE setting, the heater duty cycle is reduced or disabled to prevent overheating.

Status indicators include SUPPLY and HEAT. These perform the same functions as those on the APS-3C front panel.

Figure 5 shows the RCU-3 layout.

## RCU-4 Remote Control

The RCU-4 Remote Control Unit is used with the APS-4C and SC-40C. It adds remote control and status display to the APS-4C or SC-40C controls at a location convenient to personnel capable of observing snow melting system operation.

Snow, slush or ice, either alone or in combination, must contact at least one sensor to start melting. Heater operation continues until all sensors are dry. Depending on the rate of fall, snow density, wind velocity, power density and other factors, heater operation must continue for a period of time after the last sensor dries off. Slush tracked by vehicle and pedestrian traffic along with blowing and drifting snow are problems that are hard to predict.

The cycle timer in the APS-4C/SC-40 begins when the last sensor dries off and continues for an adjustable period of up to 10 hours to keep the heaters operating until the pavement is completely dry. Otherwise, residual water could re-freeze and create a hazardous condition.

The RCU-4 provides a two, four, six or eight hour CYCLE TIME adjustment that is independent of the cycle times in the APS-4C and SC-40C. This allows treatment of the condition requiring extra heating as the exception rather than the rule thus minimizing energy.

Operating the HEATER CYCLE switch operates heaters for the CYCLE TIME which is normally set to 2 hours. Operating the HEATER CYCLE switch during the cycle time stops the timer. If the pavement or ambient temperature exceeds the APS-4C or SC-40C HIGH LIMIT TEMPERATURE setting, the heater duty cycle is reduced or disabled to prevent overheating.

Status indicators include SUPPLY and HEAT. These perform the same functions as those on the APS-4C front panel.

The GFEP switch performs the same functions and operates in the same manner as the ones on the front panels of the APS-4C and SC-40C. In the event of an unacknowledged GFEP, the HEAT indicator flashes.

Figure 5 shows the RCU-4 layout.

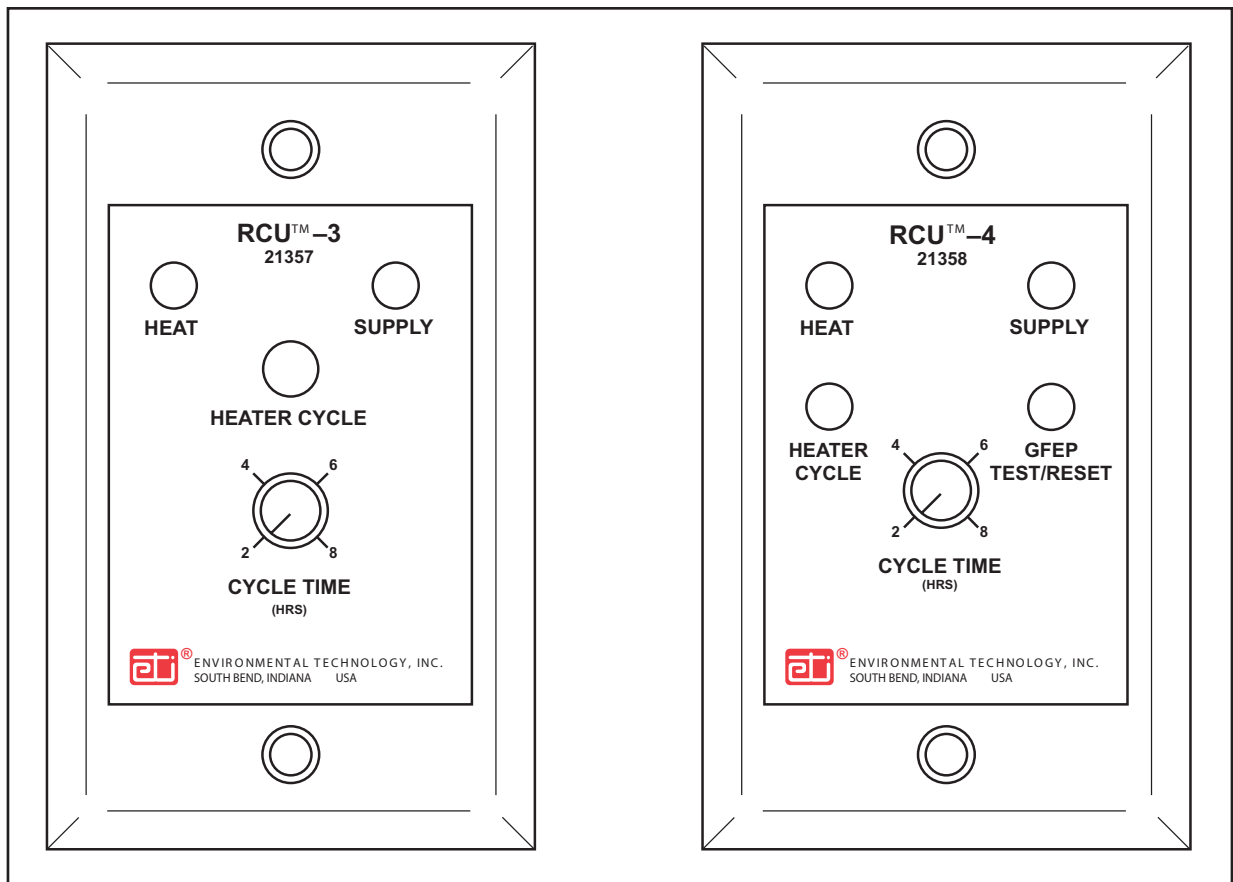

Figure 5: RCU-3 and RCU-4

## SPECIFICATIONS

All Specifications apply to APS-3C, APS-4C and SC-40C panels unless stated otherwise.

### General

Area of use	Nonhazardous locations
Approvals	 Type 873 Temperature Regulating Equipment

### Enclosure

Protection	NEMA 3R
Cover attachment	Hinged polycarbonate cover, lockable
Entries	APS-3C: 3 × 1-1/16" entries (277 VAC Single Phase ONLY) APS-4C and SC-40C: 1x1/16" entry (top) for NEC Class 2 connections 2x1-11/16" entries (bottom) for supply and load power (except for 277 VAC Single Phase)
Material	Polycarbonate
Mounting	Wall mounted

### Control

Supply	APS-3C: ETI PN 22470: 120 VAC, 50/60 Hz, 35 VA ETI PN 22471: 208-240 VAC, 50/60 Hz, 35 VA APS-4C: ETI PN 22472: 208-240 VAC, 35 VA, three phase 50/60 Hz ETI PN 22473: 277 VAC, 45 VA, single phase 50/60 Hz ETI PN 22475: 277/480 VAC, 45 VA, three phase 50/60 Hz ETI PN 22476: 600 VAC, 50 VA, three phase 50/60 Hz SC-40C: ETI PN 22477: 208-240 VAC, 35 VA, three phase 50/60 Hz ETI PN 22478: 277 VAC, 45 VA, single phase 50/60 Hz ETI PN 22480: 277/480, 45 VA, three phase 50/60 Hz ETI PN 22481: 600 VAC, 50 VA, three phase 50/60 Hz
Load	APS-3C: ETI PN 22470: 120 VAC, 24 amp max. inductive ETI PN 22471: 208-240 VAC, 24 amp max. inductive APS-4C: ETI PN 22472: 208-240 VAC, 50 amp max. resistive ETI PN 22473: 277 VAC, 40 amp max. resistive ETI PN 22475: 277/480 VAC, 50 amp max. resistive ETI PN 22476: 600 VAC, 50 amp max. resistive SC-40C: ETI PN 22477: 208-240 VAC, 50 amp max. resistive ETI PN 22478: 277 VAC, 40 amp max. resistive ETI PN 22480: 277/480, 50 amp max. resistive ETI PN 22481: 600 VAC, 50 amp max. resistive
Contact type	APS-3C: Form C APS-4C and SC-40C: 3 Form A
Maximum Ratings	APS-3C: Voltage: 240 VAC Current: 24 amps APS-4C and SC-40C: Voltage: 600 VAC Current: 50 amps
Heater hold-on timer	0 to 10 hours; actuated by snow stopping or toggle switch
System test	Switch toggles the heater contact on and off. If temperature exceeds high limit, heater cycles to prevent damage.

### Snow/Ice Sensors

Sensor type	Up to 6 sensors from the CIT-1 product family
Circuit type	NEC Class 2
Lead length	Up to 500' (152m) using 18 AWG 3-wire jacketed cable Up to 2,000' (609m) using 12 AWG 3-wire jacketed cable

### High Limit Thermostat

Adjustment range	40°F to 90°F (4°C to 32°C)
Dead band	1°F (0.6°C)

Sensor type	Thermistor network
Circuit type	NEC Class 2
Lead length	Up to 500' (152m) using 18 AWG 2-wire jacketed cable Up to 1,000' (304m) using 12 AWG 2-wire jacketed cable

**Energy Management Computer (EMC) Interface**

Inputs	OVERRIDE ON (10 ma dry switch contact) OVERRIDE OFF (10 ma dry switch contact)
Outputs	SUPPLY (10 ma dry switch contact) SNOW (10 ma dry switch contact) HEAT (10 ma dry switch contact) HIGH TEMP (10 ma dry switch contact) ALARM (10 ma dry switch contact)

**Environmental**

Operating temperature	-40°F to 160°F (-40°C to 71°C)
Storage temperature	-50°F to 180°F (-45°C to 82°C)

**Ground Fault Equipment Protection (GFEP)(APS-4C and SC-40C only)**

Set point	30 mA (default); 60 mA and 120 mA selectable by DIP switch
Automatic self-test	Mode A: Verifies GFEP function before contactors operate Mode B: Verifies GFEP and heaters every 24 hours
Manual test/reset	Toggle switch provided for this function
Maintenance facility	DC output proportional to ground current provided for troubleshooting the heater system

**Communication Bus (SC-40C only)**

Number of cascaded units	Unlimited
Contactors delay	5 second
Bus-wire type	3-wire jacketed cable
Circuit type	NEC Class 2
Lead Length	Up to 500' (152m) using 18 AWG 3-wire jacketed cable Up to 1,000' (304m) using 12 AWG 3-wire jacketed cable

## Operation

### APS-3C

The snow melting system can be monitored and controlled either locally from the APS-3C itself or from two remote locations including:

- RCU-3 Remote Control Unit
- BEMC

### Local Control from the APS-3C

#### Indicators:

- SUPPLY (green) shows that power is present.
- SNOW (yellow) shows that there is a snow/ice signal originating from at least one of the CIT-1, GIT-1 and/or SIT-6E sensors attached to the system.
- HEAT (yellow) shows that there is a call for heat. This happens during snow and for the hold-on time thereafter or when the heater cycle switch is operated.
- EMC (yellow) shows that the interfaced Energy Management Computer is presently overriding local system control.
- TEMP LIMIT (red) shows that either the pavement temperature is above the set HIGH TEMPERATURE LIMIT and there is a call for HEAT or the ambient air temperature is above the set HIGH TEMPERATURE LIMIT. The APS-3C can be configured to monitor slab temperature or ambient air temperature but not both.
- GFEP (red, blinking) shows that there is a GFEP condition present on an attached SC-40 Satellite Contactor.

#### Adjustments:

- HOLD-ON TIME adjustment sets the time that heaters operate after snow stops. Doing this is necessary to make certain the pavement dries before heating ceases. This prevents refreezing. Try an initial setting of 3-5 hours. Increase, if necessary. Reduce with care since energy savings are being traded for an increased likelihood of refreezing.
- HIGH-LIMIT TEMPERATURE adjustment sets the maximum deicing temperature.

#### Switches:

- HEATER CYCLE switch momentarily toggled down will start a manual heater cycle for the set HOLD-ON TIME or restart the HEATER CYCLE if on was already in progress. Momentarily toggled up will cancel a heater cycle if one is in progress.

### Remote Control from the RCU-3

#### Indicators:

- SUPPLY (green) shows that power is present.
- HEAT (yellow) shows that there is a call for heat. This happens during snow and for the hold-on time thereafter or when the heater cycle switch is operated.

#### Adjustments:

- CYCLE TIME adjustment sets the time heaters will operate when HEATER CYCLE switch is momentarily depressed at the RCU-3.

## Switches:

- HEATER CYCLE switch momentarily depressed will start a manual heater cycle for the set CYCLE TIME. Momentarily depressed while heaters are being operated by a hold-on timer or during manual heater cycle will end the heater cycle. Heater operation during snow conditions cannot be canceled in this manner.

## Remote Control from the EMC Interface

The EMC interface is identical on all of the APS "C" Series models. Please see the EMC section of the manual for interface details.

## APS-4C and SC-40C

The snow melting system can be monitored and controlled either locally from the APS-4C itself or from two remote locations connected to the APS control panel including:

- RCU-4 Remote Control Unit
- EMC

Control initiated from an SC-40C is local to the heater(s) connected to that panel and will not affect the operation of heaters attached to the APS control panel or other SC-40C contactors in the system. This includes remote control operation from an RCU-4 or EMC connected to an SC-40.

## Local Control for the APS-4C or SC-40C

### Indicators:

- SUPPLY (green) shows that power is present.
- SNOW (yellow) shows that there is a snow/ice signal originating from at least one of the connected CIT-1, GIT-1 and/or SIT-6E sensors attached to the system.
  - HEAT (yellow) shows that there is a call for heat. This happens during snow and for the hold-on time thereafter or when the heater cycle switch is operated.
  - EMC (yellow) shows that the interfaced Energy Management Computer is presently overriding local system control.
  - TEMP LIMIT (red) shows that either the pavement temperature is above the set HIGH TEMPERATURE LIMIT and there is a call for HEAT or the ambient air temperature is above the set HIGH TEMPERATURE LIMIT. The APS-4C can be configured to monitor ambient air temperature or slab temperature but not both.
  - GFEP (red) shows that there is a GFEP condition present on the local APS-4C Control Panel or SC-40 Satellite Contactor.
    - GFEP (red, blinking) shows that there is a GFEP condition present on an attached SC-40 Satellite Contactor.

### Adjustments:

- HOLD-ON TIME adjustment sets the time that heaters operate after snow stops. Doing this is necessary to make certain the pavement dries before heating ceases. This prevents refreezing. Try an initial setting of 3-5 hours. Increase, if necessary. Reduce with care since energy savings are being traded for an increased likelihood of refreezing.
  - HIGH-LIMIT TEMPERATURE adjustment sets the maximum deicing temperature.

### Switches:

- GFEP TEST switch momentarily toggled down will start a test of the ground

fault circuitry of that APS-4C or SC-40C. Momentarily toggled up will RESET a ground fault condition at that APS-4C or SC-40C.

- HEATER CYCLE switch momentarily toggled down will start a manual heater cycle for the set HOLD-ON TIME or restart the HEATER CYCLE if on was already in progress. Momentarily toggled up will cancel a heater cycle if one is in progress.

## Remote Control from the RCU-4

### Indicators:

- SUPPLY (green) shows that power is present.
- HEAT (yellow) shows that there is a call for heat. This happens during snow and for the hold-on time thereafter or when the heater cycle switch is operated.

### Adjustments:

- CYCLE TIME adjustment sets the time heaters will operate when HEATER CYCLE switch is momentarily depressed at the RCU-4.

### Switches:

- GFEP TEST/RESET switch momentarily depressed when there is no ground fault condition will start a test of the ground fault circuitry of that APS-4C or SC-40C. Momentarily depressed when there is a ground fault condition at the attached APS-4C or SC-40C will RESET a ground fault condition at that APS-4C or SC-40C and start a test of the ground fault circuitry of that APS-4C or SC-40C.
- HEATER CYCLE switch momentarily depressed will start a manual heater cycle for the set CYCLE TIME. Momentarily depressed while heaters are being operated by a hold-on timer or during manual heater cycle will end the heater cycle. Heater operation during snow conditions cannot be canceled in this manner.

## Remote Control from the EMC Interface

The EMC interface is identical on all of the APS "C" Series models. Please see the EMC section of the manual for interface details.

## Energy Management Computer (EMC) Interface

The APS "C" Series provides an EMC interface to communicate with the EMC of building automation systems. The EMC interface provides 10 mA dry switch contacts for communicating status to the EMC or starting or stopping the system from the EMC.

### EMC interface outputs:

- Output Common
- HEAT indicates that there is a call for heat. This happens during snow and for the hold-on time thereafter or when the heater cycle switch is operated.
- SNOW indicates that there is a snow/ice signal originating from at least one of the connected CIT-1, GIT-1 and /or SIT-6E sensors attached to the system.
- ALARM
- SUPPLY indicates that power is present.
- TEMP LIMIT indicates that either the pavement temperature is above the set HIGH TEMPERATURE LIMIT and there is a call for HEAT or the ambient air temperature is above the set HIGH TEMPERATURE LIMIT. An APS "C" Series control can be configured to monitor slab temperature or ambient air temperature but not both.

### DIP Switch Settings GFEP

DIP Switch Settings			
1	2	3	4
Off	Off	----	----

30 mA (Factory Default)

DIP Switch Settings			
1	2	3	4
Off	On	----	----

60 mA

DIP Switch Settings			
1	2	3	4
On	Off	----	----

120 mA

DIP Switch Settings			
1	2	3	4
On	On	----	----

GF disabled

Figure 7: DIP Switch GFEP Threshold Settings

### EMC interface inputs:

- **VERRIDE ON** can be used to override an attached APS “C” Series control in order to turn heaters on. A normal contact closure will turn on heaters until operation is cancelled. If the EMC cycles the **VERRIDE ON** relay on and off again within more than 32 milliseconds but less than 300 milliseconds the attached APS “C” Series control will begin a manual heater cycle and run for the **HOLD-ON TIME** set at the panel.

- **VERRIDE OFF** can be used to override an attached APS “C” Series control in order to turn heaters off. A normal contact closure will turn off heaters. If the EMC cycles the **VERRIDE OFF** relay on and off again within more than 32 milliseconds but less than 300 milliseconds the attached APS “C” Series control will end a manual heater cycle.

### Installation

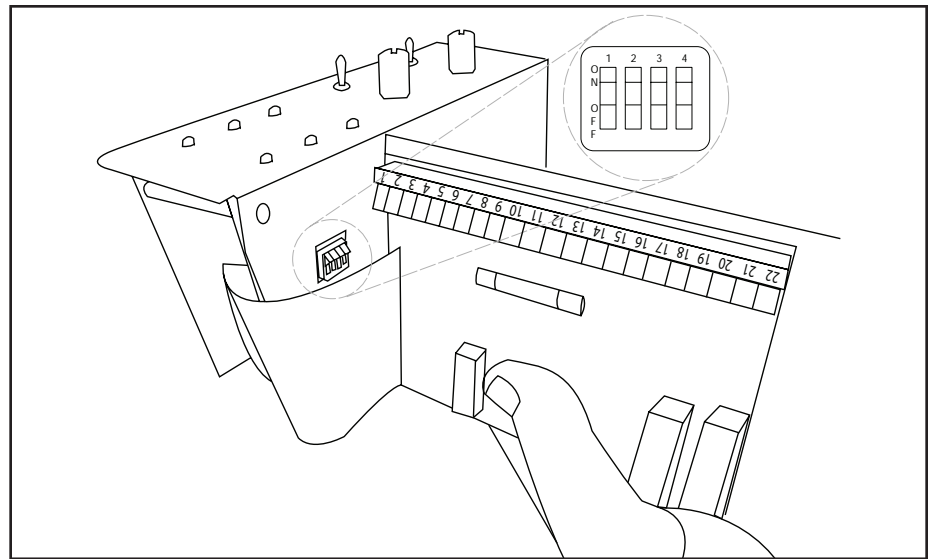

Figure 6: Location of DIP Switch

### Jumper Settings

#### Configuring GFEP Threshold

DIP switch pins 1 and 2 are utilized to set GFEP threshold. On the APS-4C and SC-40C the integrated GFEP can be set to 30 mA, 60 mA, 120 mA or off. Factory default is 30 mA. This feature is not available on APS-3C control panels. Figure 7 shows how to configure GFEP option at the DIP switch.

#### Configuring the High Limit Thermostat

Dip Switch pin 3 is used to set the high limit thermostat operation to one of two possible operational modes:

- **OFF** sets the high limit thermostat as a slab regulating temperature sensor.
- **ON** sets the high limit thermostat as an ambient air sensor. **OFF** is the factory default.

Figure 8 shows how to configure the high limit thermostat mode at the DIP switch.

### DIP Switch Settings HLT

DIP Switch Settings			
1	2	3	4
----	----	Off	----

Slab Regulating Temp. Sensor

DIP Switch Settings			
1	2	3	4
----	----	On	----

Ambient Air Sensor

Figure 8: DIP Switch Settings for High Limit Thermostat



## Factory Use Only

DIP switch pin 4 is for factory use only. The use of pin 4 except by authorized personnel may lead to improper operation of the APS-3C, APS-4C or SC-40C.

## Bypassing the High Limit Temperature Sensor

If, for any reason, you need to operate the system without the High Limit Temperature Sensor (for trouble shooting or while waiting for a replacement sensor) you can temporarily replace the sensor with a 470K resistor. The resistor will allow the system to run as if the sensed temperature was 40°F (4.4°C).

Refer to Figure 23 for placement of resistor.

## Reading the GFEP Current

The GFEP current being sensed by an APS-4C or SC-40C can be measured using a standard hand-held digital volt meter (DVM). Attach the DVM (reading DC voltage up to 2 volts) to pins 12 and 13. The DVM reading will be scaled 0.01 VDC= 1 mA. A typical reading then may be 0.3 VDC which would equal a GFEP current of 30 mA.

As long as no ground fault condition exists, the DVM reading will change in real time. In the case of a ground fault condition the reading at the time of the ground fault will be read until GFEP is reset on the panel or until power is cycled.

Refer to Figure 21 for DVM connections.

# APS-3C Line Connections

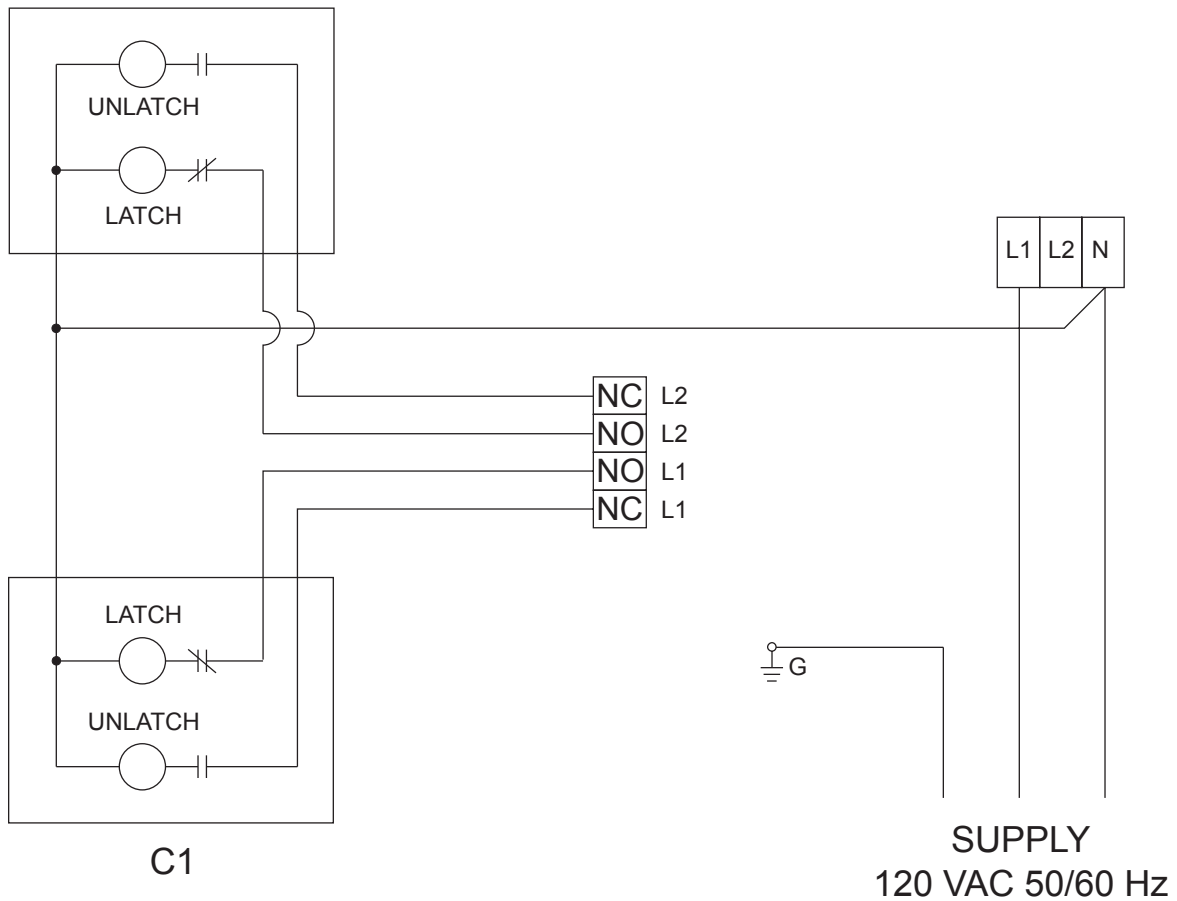
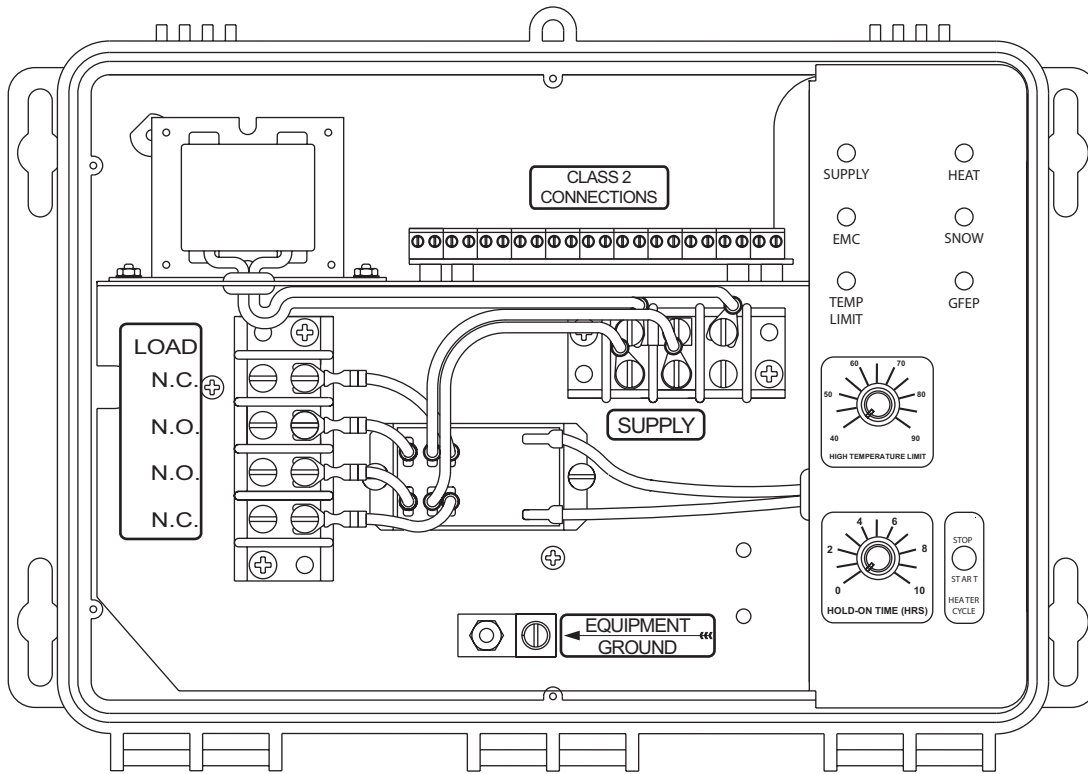

Figure 9: 120 VAC APS-3C Operating a mechanically held contactor

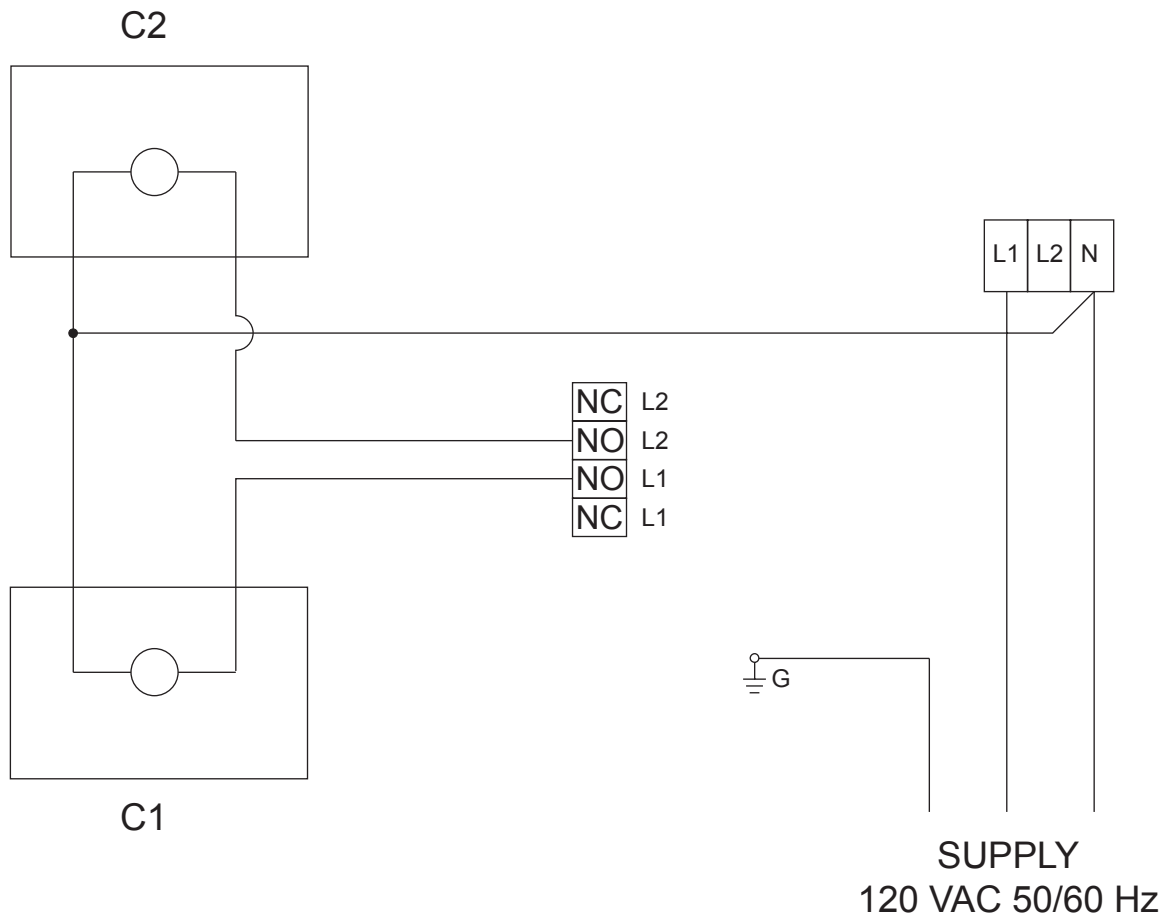
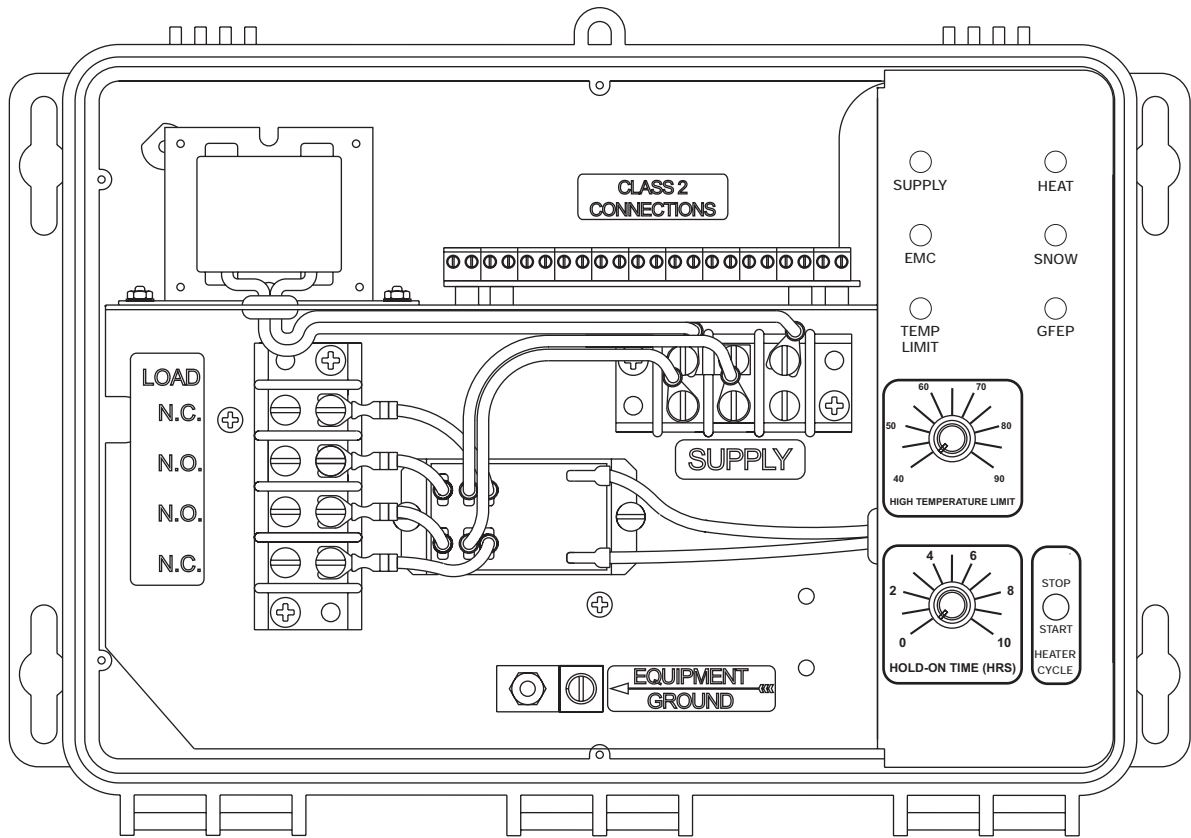

Figure 10: 120 VAC APS-3C Operating two electrically held contactors

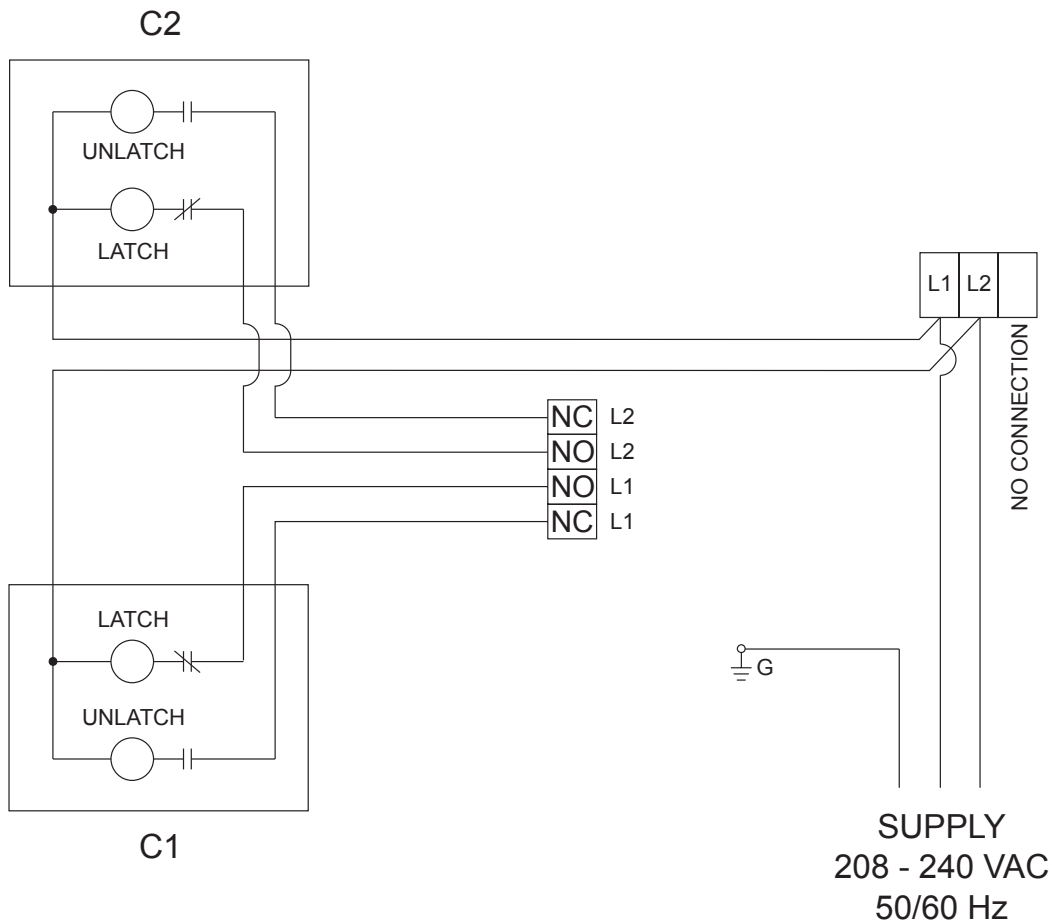
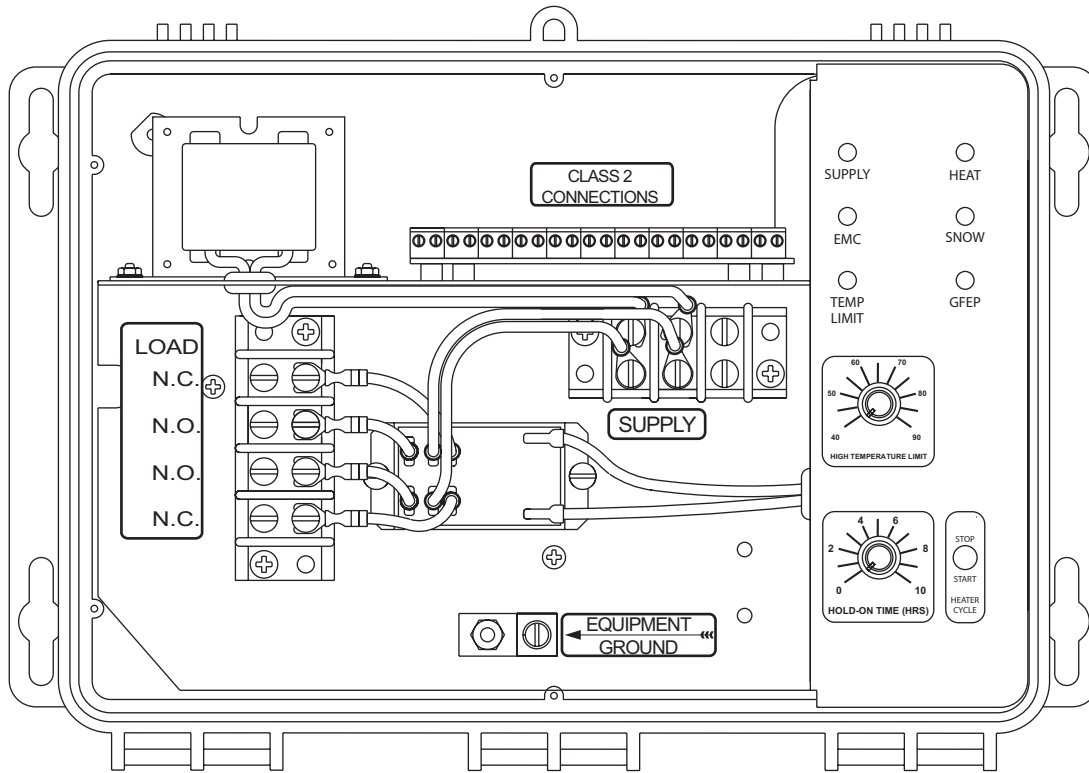
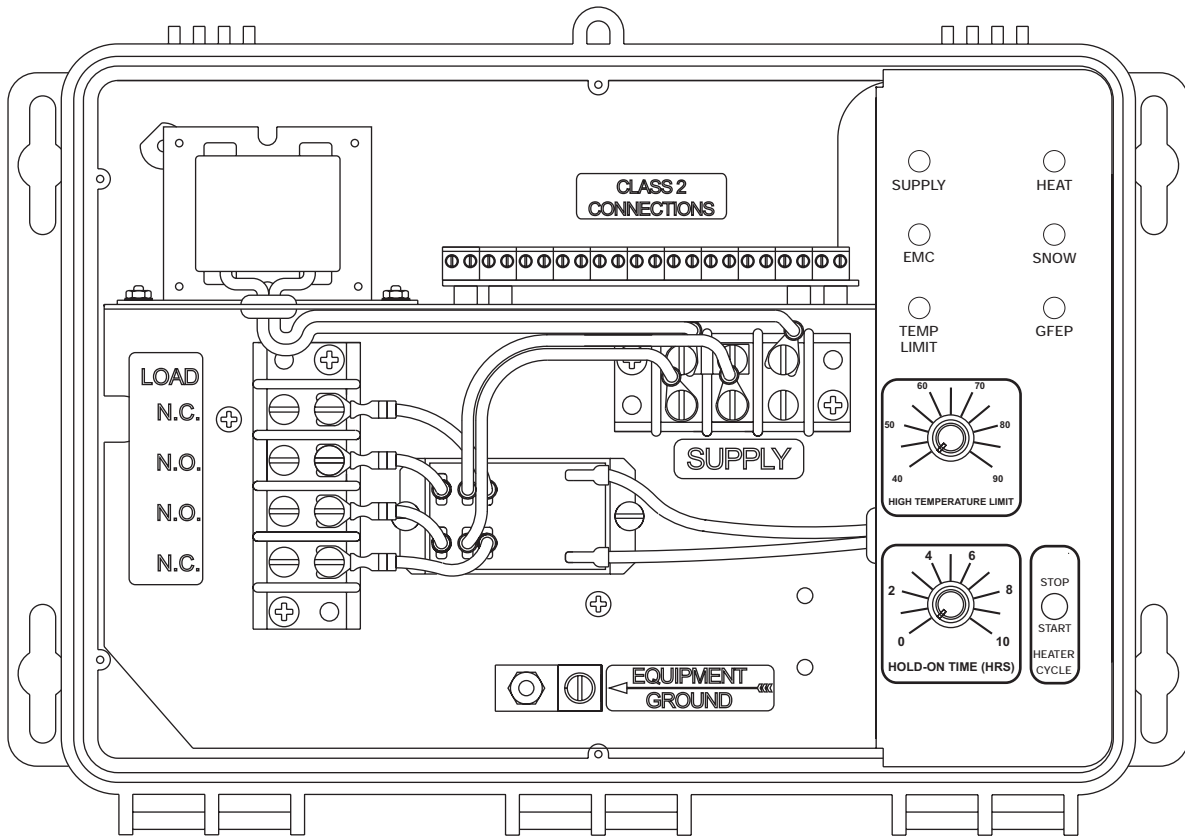

Figure 11: 240 VAC APS-3C Operating mechanically held contactors



C2

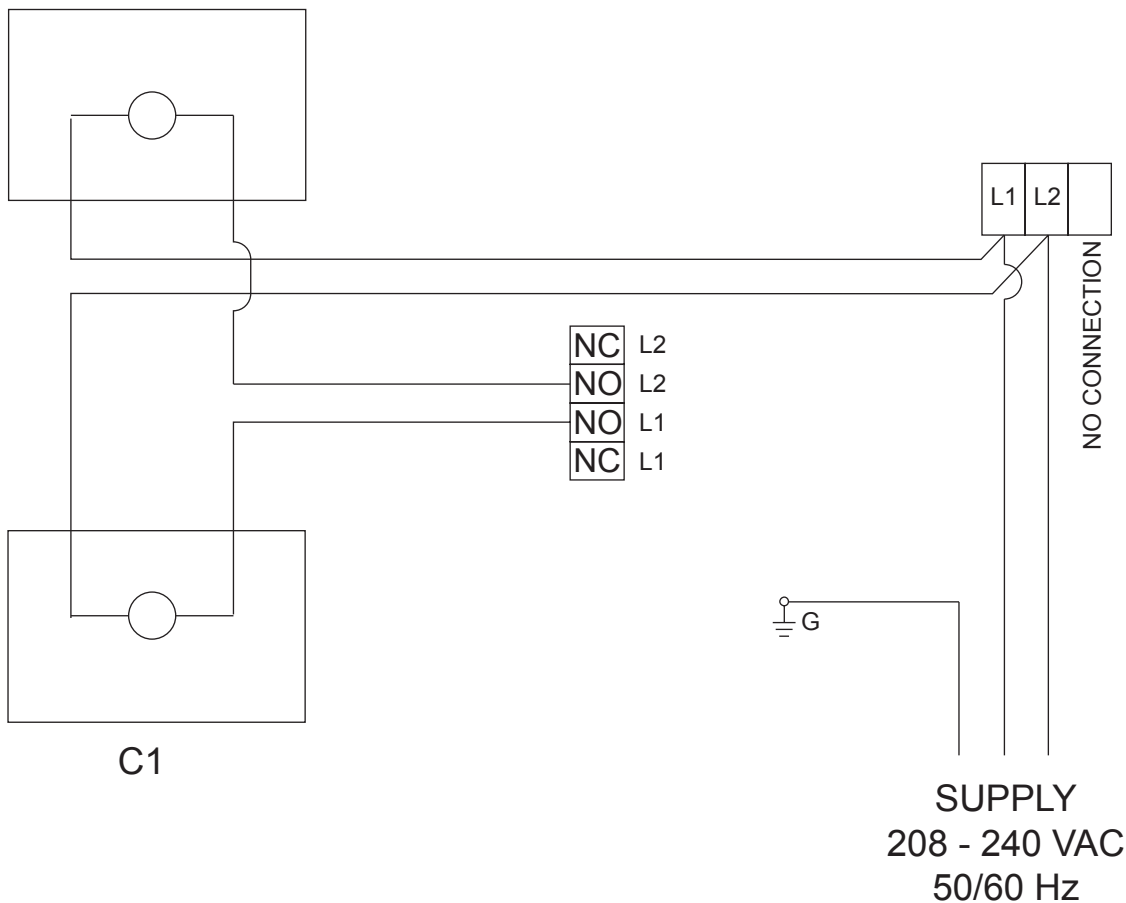

Figure 12: 240 VAC APS-3C Operating two electrically held contactors

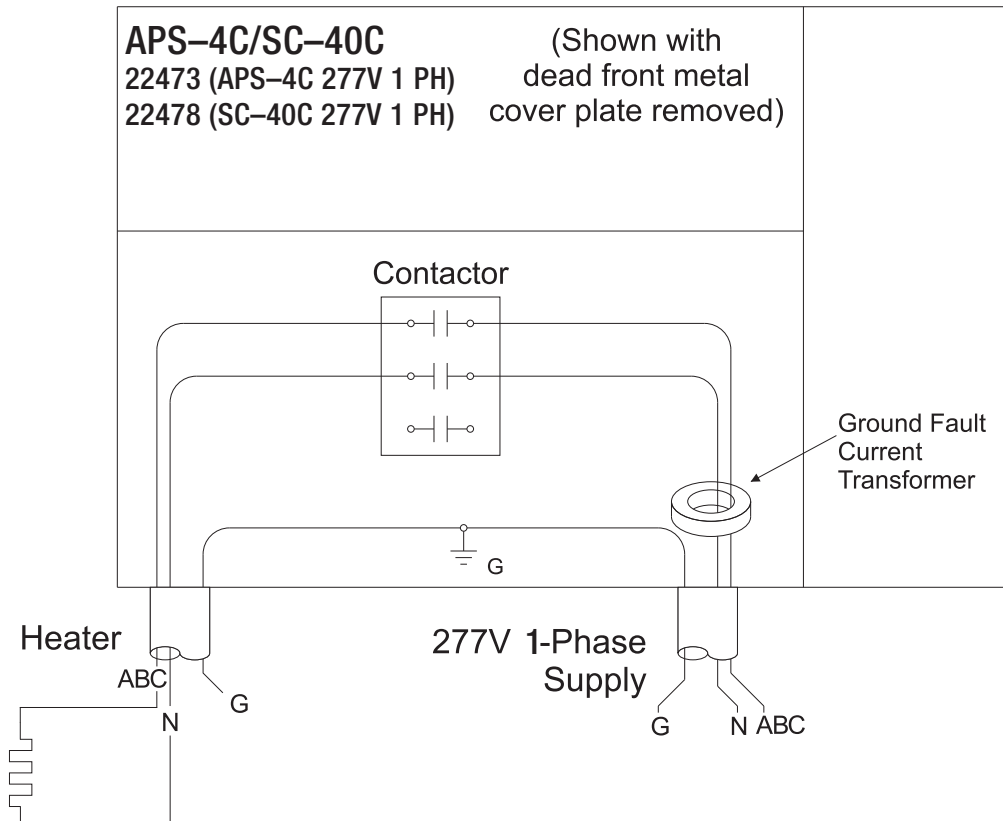
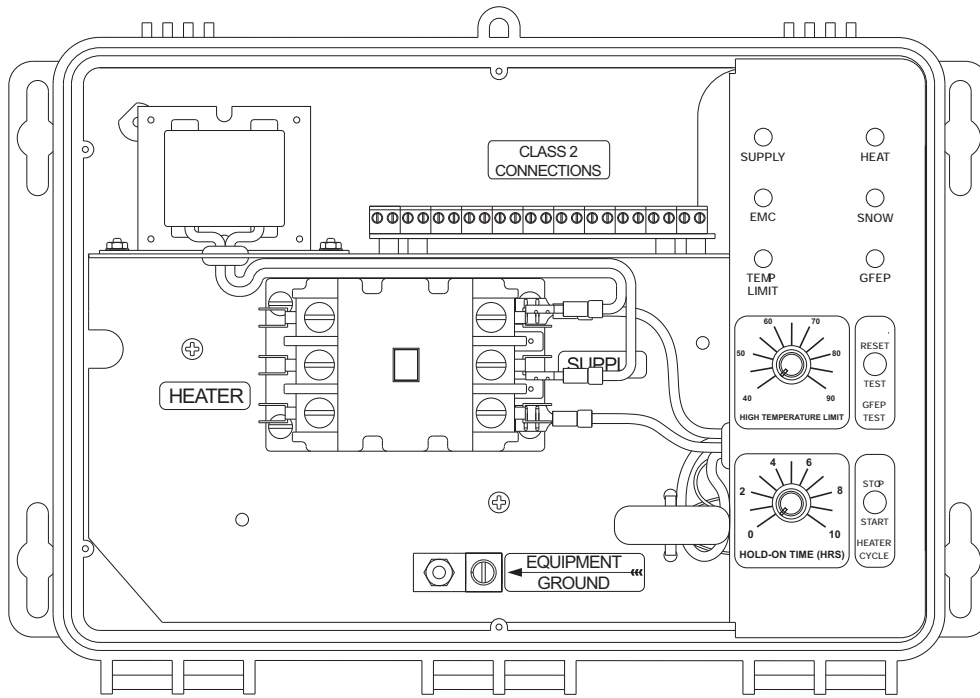

Figure 13: APS-4C and SC-40C 277 VAC Single Phase Heater Connect

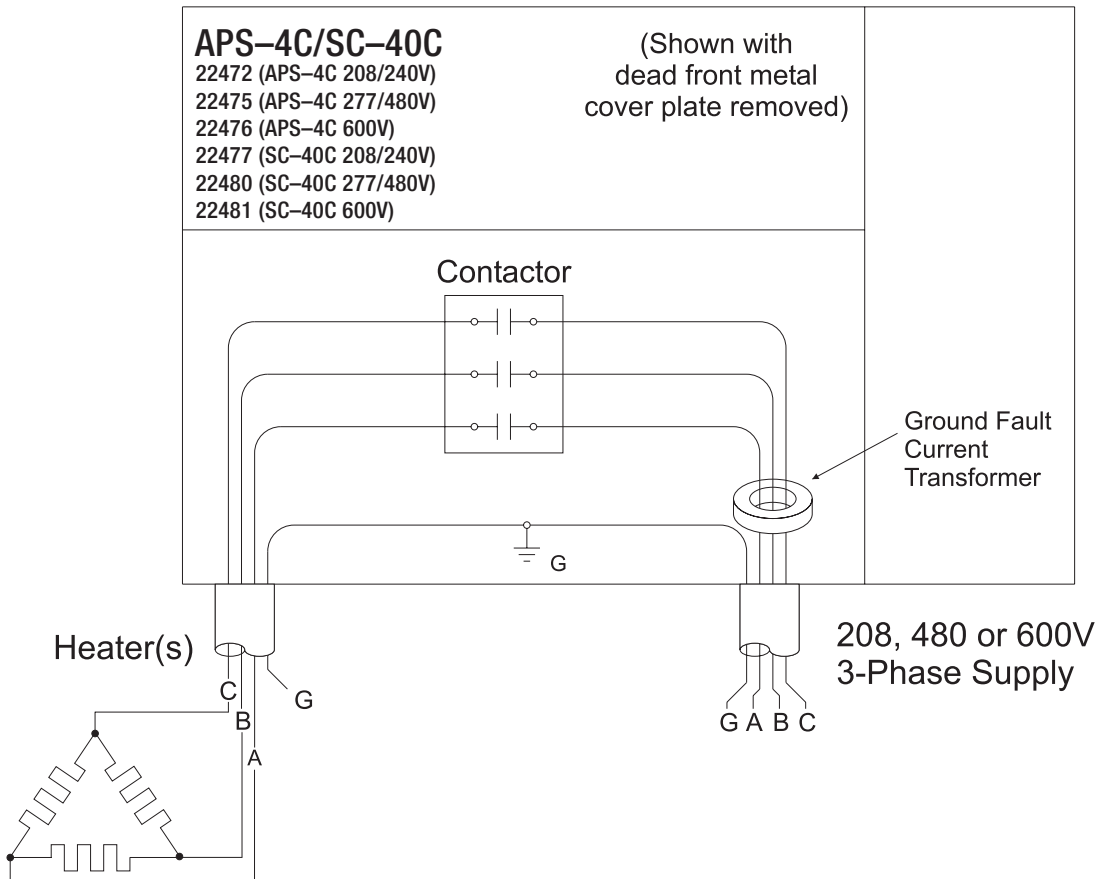
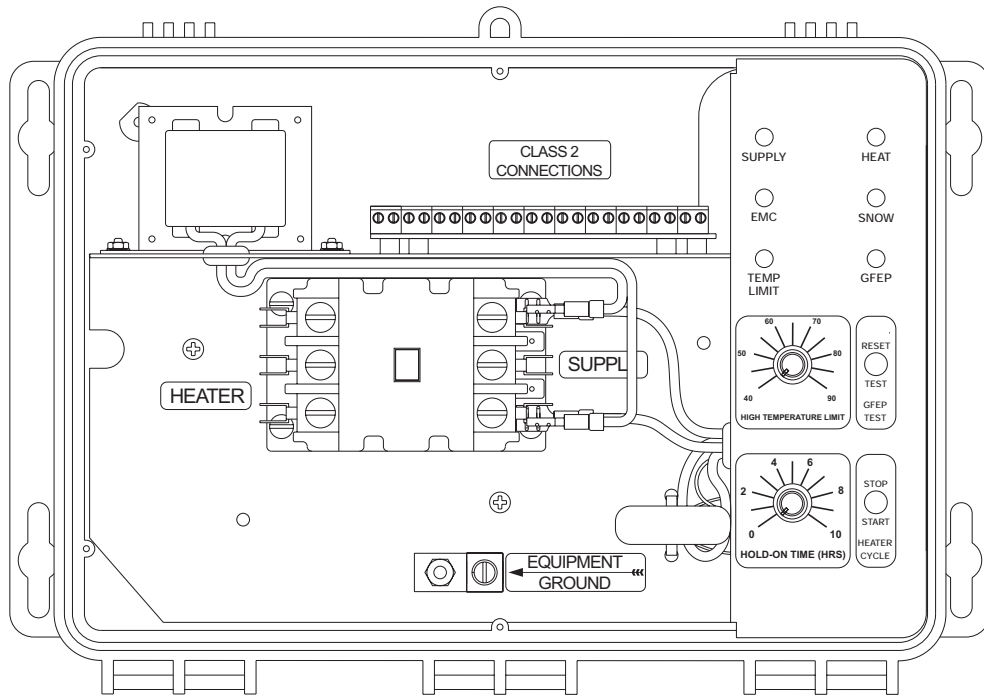

Figure 14: APS-4C and SC-40C Three Phase Delta

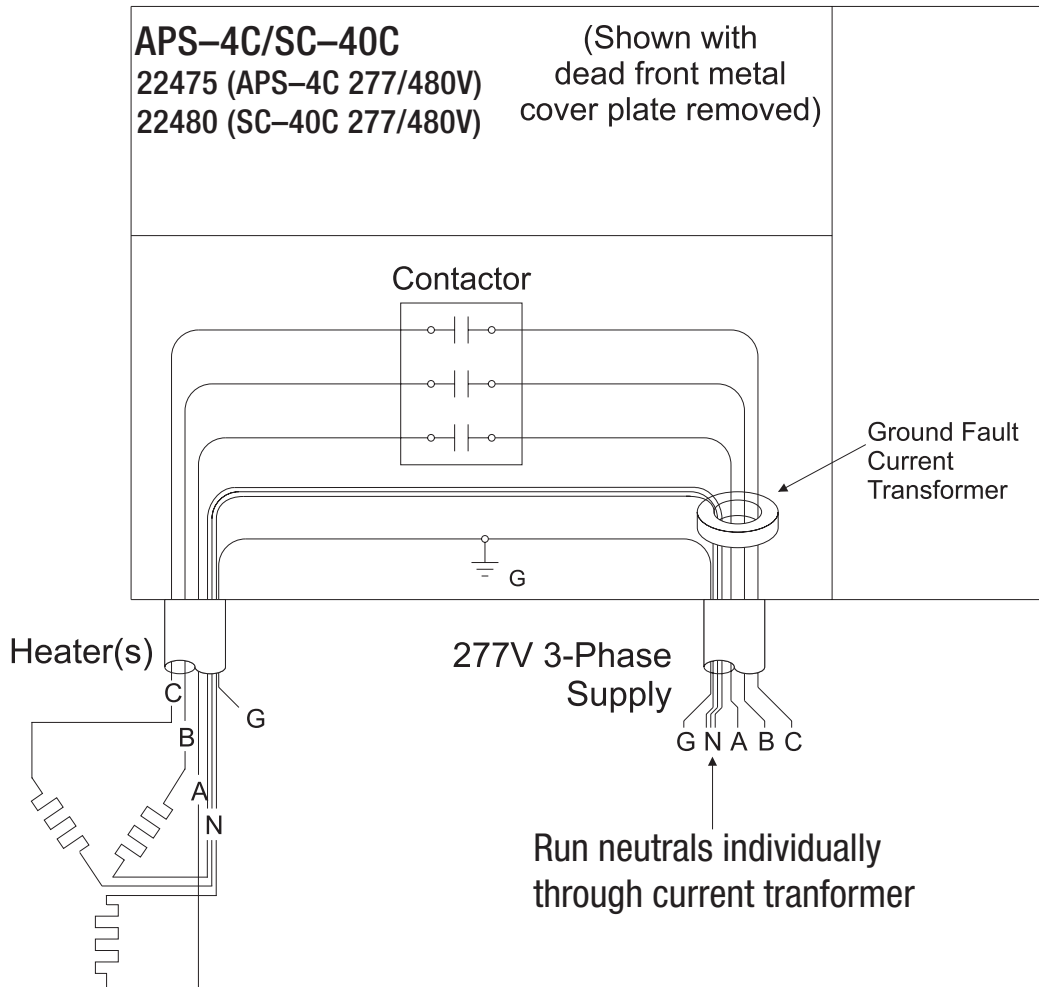
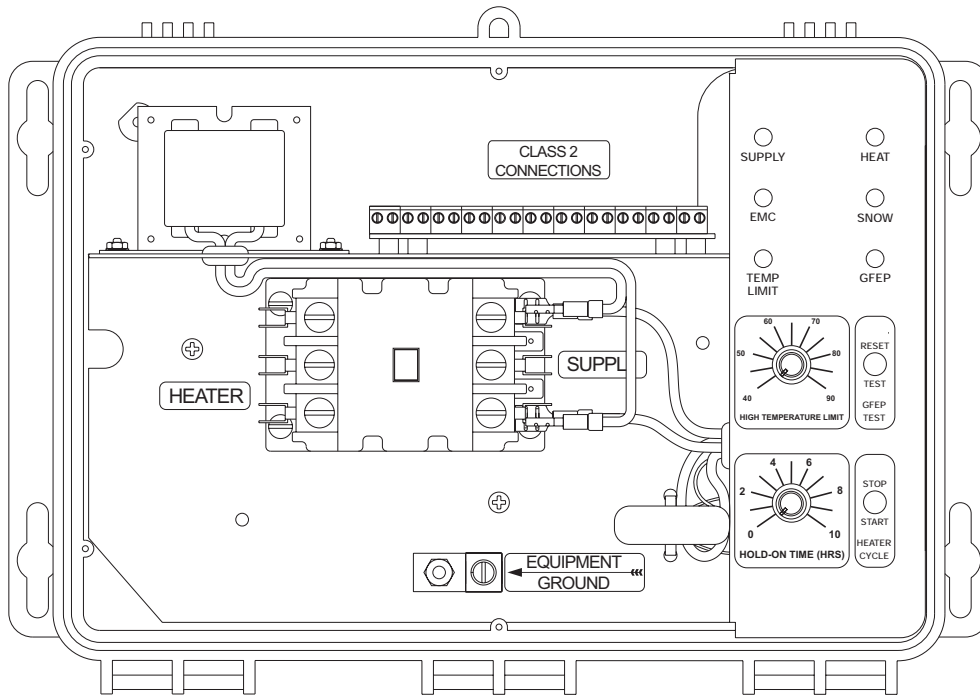

Figure 15: APS-4C and SC-40C Three Phase Wye



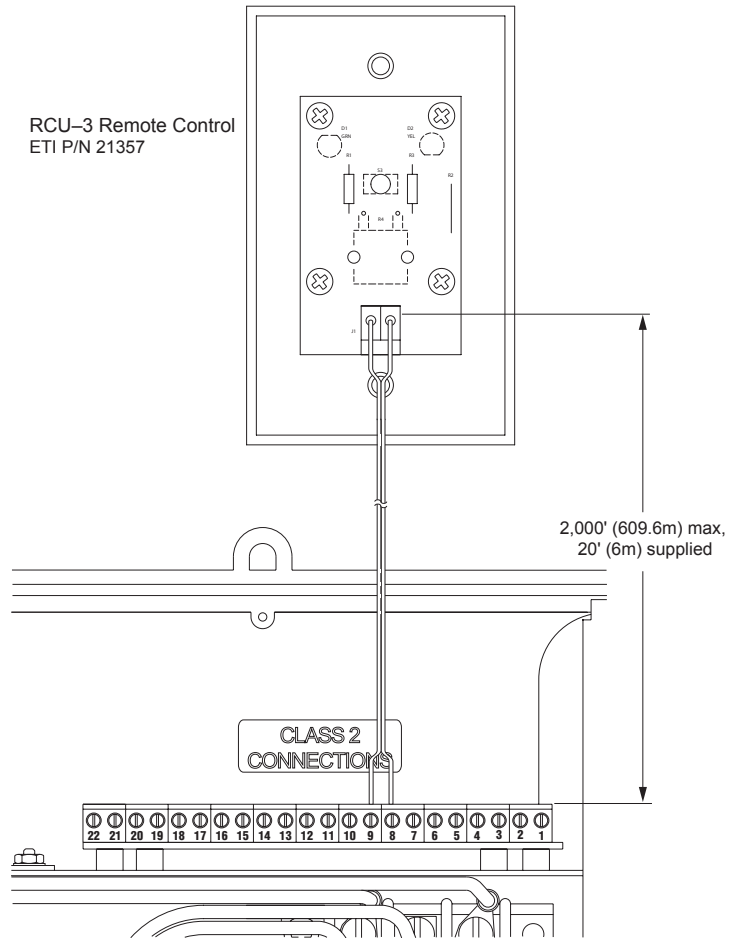

Figure 16: APS-3C & RCU-3 remote connection

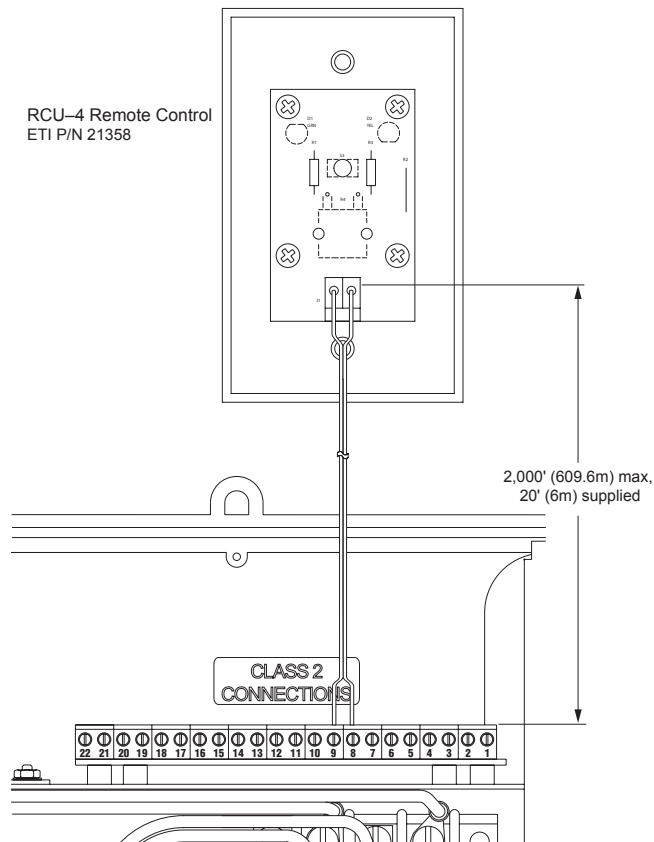

Figure 17: APS-4C & RCU-4 remote connection

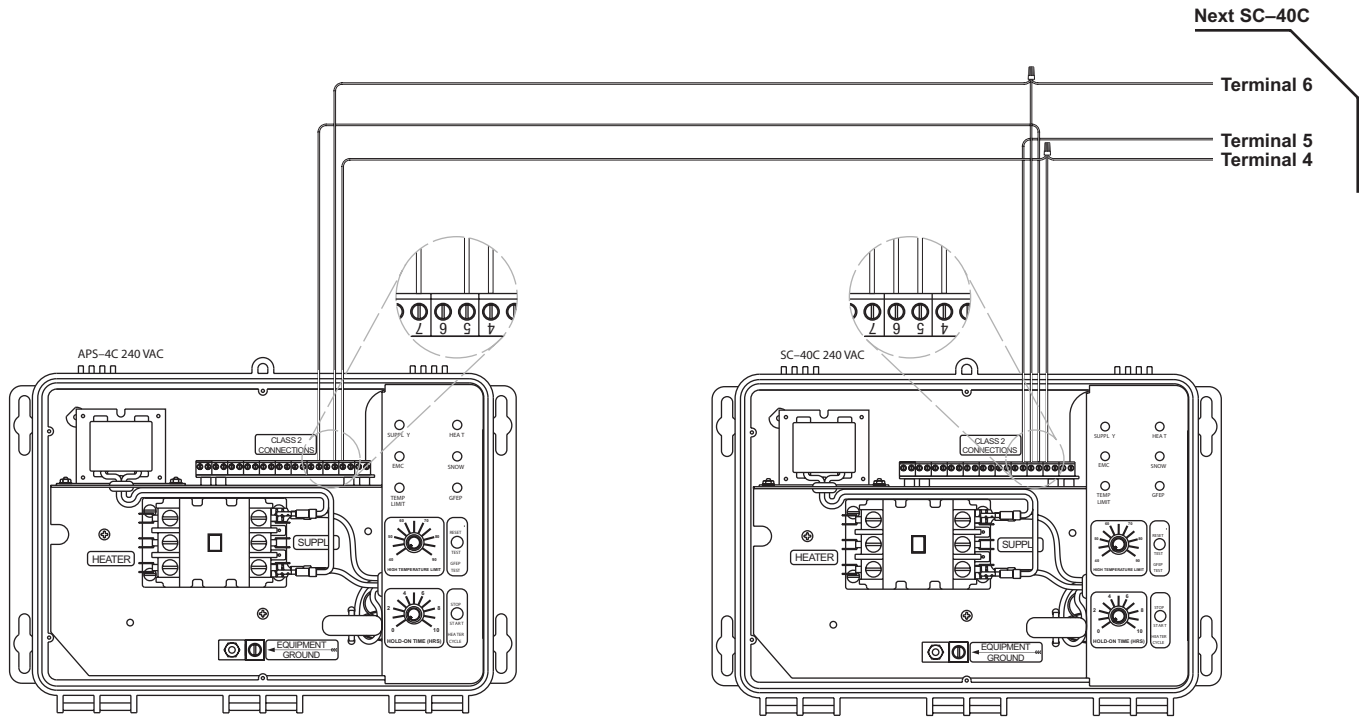

Figure 18: APS-4C/SC-40C Communication Bus Connections

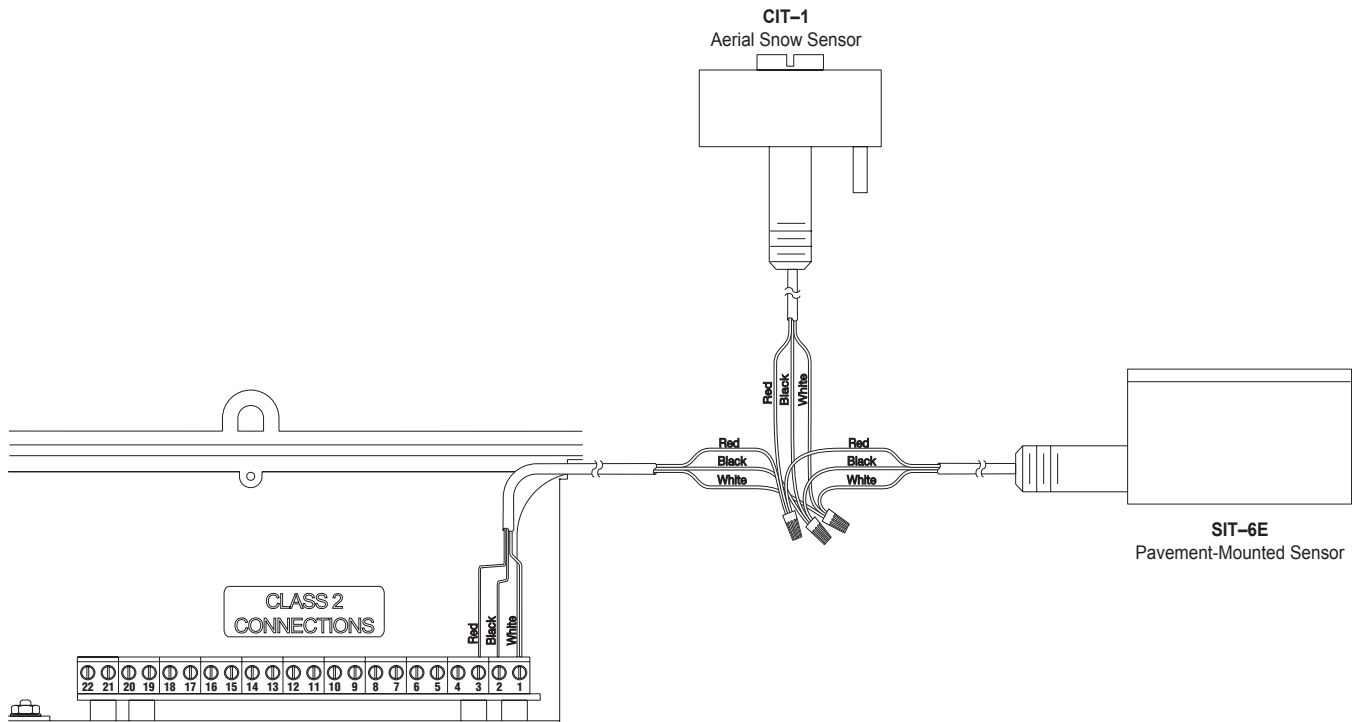

Figure 19: APS-3C/APS-4C Sensor Connections

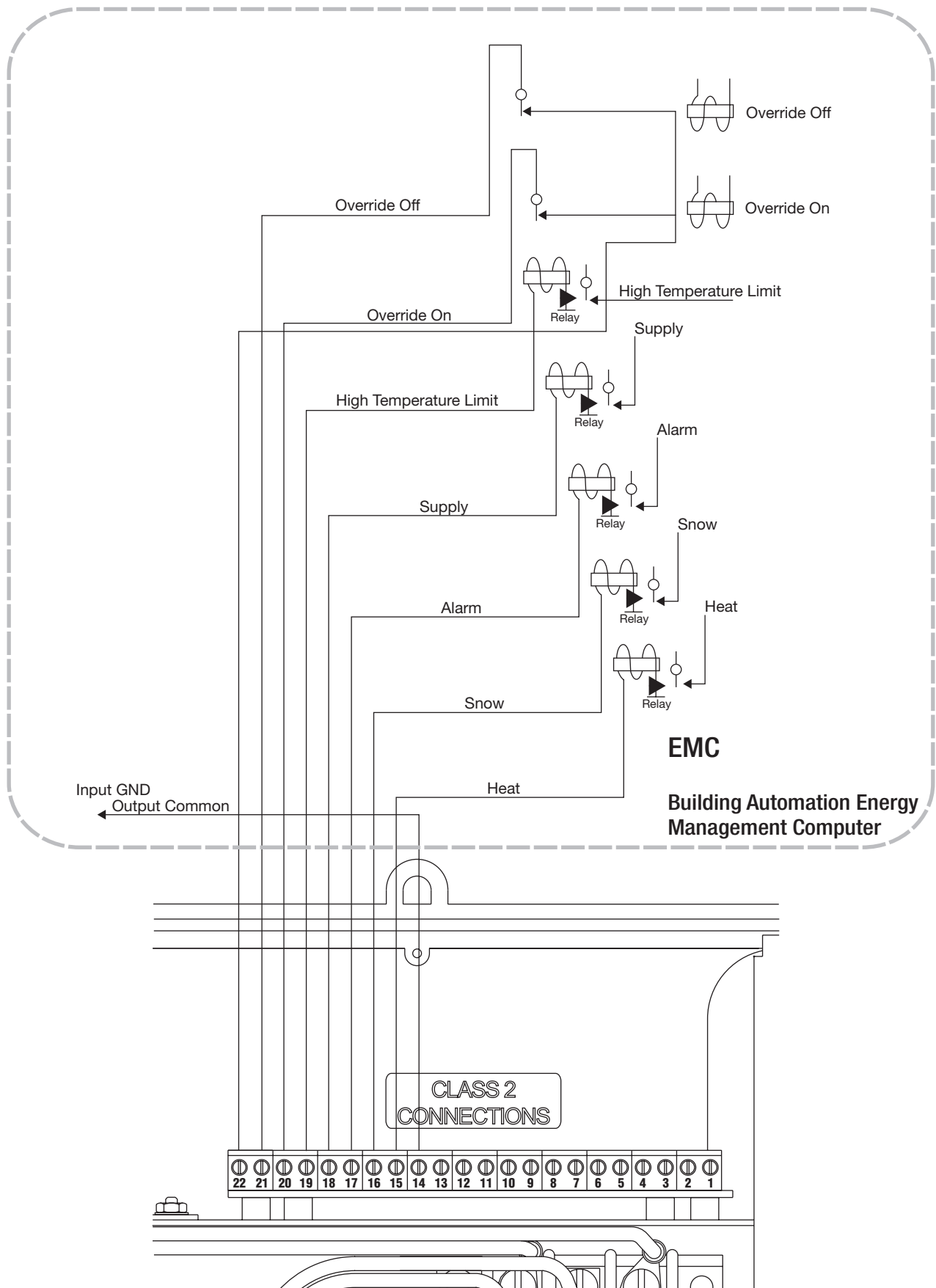

Figure 20: APS-3C/APS-4C/SC-40C EMC connections



Figure 21: APS-3C/APS-4C/SC-40C Electrician's DVM

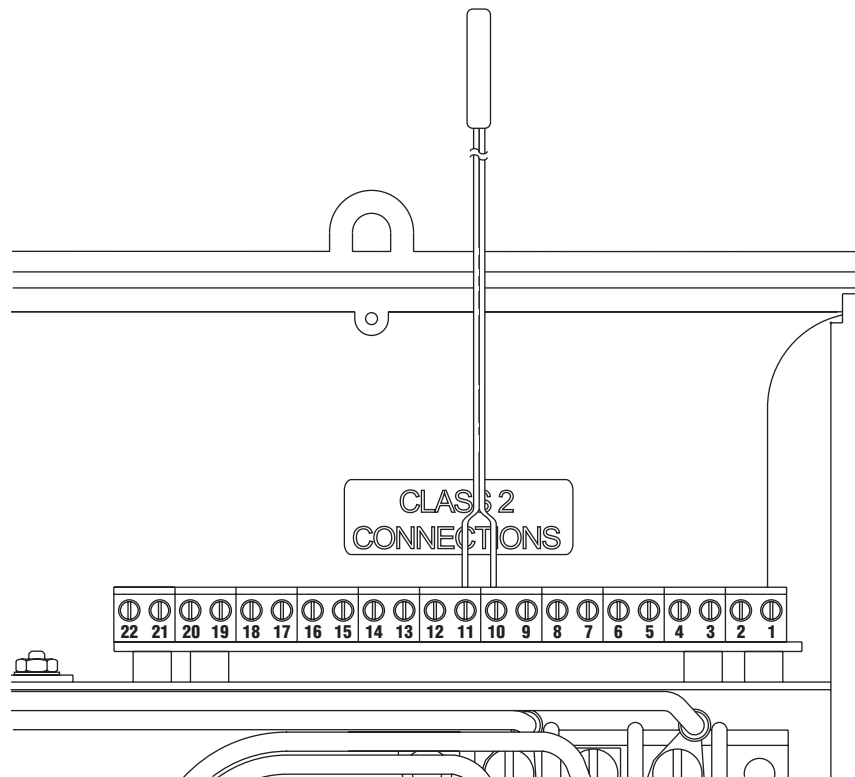

Figure 22: APS-3C/APS-4C/SC-40C Thermistor connections

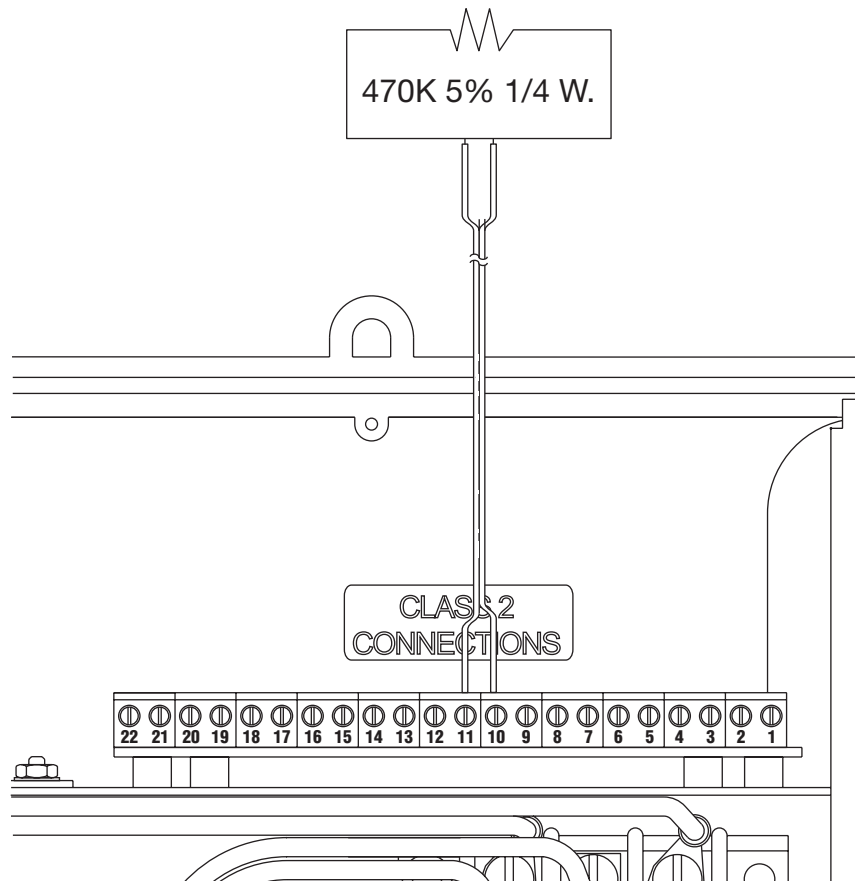

Figure 23: APS-3C/APS-4C/SC-40C Resistor connections

## Contactors Connections

<b>Contactors Number</b>	<b>Connection</b>
1	Sensor Connection (White wire)
2	Sensor Connection (Black wire)
3	Sensor Connection (Red wire)
4	Satellite Panel Connection
5	Satellite Panel Connection
6	Satellite Panel Connection
7	Satellite Panel Connection
8	RCU-3/RCU-4 Connection
9	RCU-3/RCU-4 Connection
10	Thermistor Connection
11	Thermistor Connection
12	Electrician's DVM
13	Electrician's DVM
14	Output Common
15	Heat
16	Snow
17	Alarm
18	Supply
19	High Temperature Limit
20	Override On
21	Override Off
22	Close Override On/Off Circuit

## ORDERING INFORMATION

Order Number	Description
22470	APS-3C Control Panel, 120 VAC
22471	APS-3C Control Panel, 208/240 VAC
22472	APS-4C Control Panel, 208-240 VAC 50/60 Hz Three Phase
22473	APS-4C Control Panel, 277 VAC 50/60 Hz Single Phase
22475	APS-4C Control Panel, 277/480 VAC 50/60 Hz Three Phase
22476	APS-4C Control Panel, 600 VAC 50/60 Hz Three Phase
22477	SC-40C Satellite Contactor, 208-240 VAC 50/60 Hz Three Phase
22478	SC-40C Satellite Contactor, 277 VAC 50/60 Hz Single Phase
22480	SC-40C Satellite Contactor, 277/480 VAC 50/60 Hz Three Phase
22481	SC-40C Satellite Contactor, 600 VAC 50/60 Hz Three Phase
<b>Accessories</b>	
21357	RCU-3 Remote Control (Optional; APS-3C only)
21358	RCU-4 Remote Control (Optional; APS-4C and SC-40C only)
19272	High Temperature Sensor w/ 20' (6m) lead (Qty 1 included)
22690	PTS-100 Embedded Temperature Sensor (Optional)
<b>Snow/Ice Sensors (Not Included)</b>	
10001	CIT-1 Aerial Snow Sensor
11351	GIT-1 Gutter Ice Sensor
20756	SIT-6E Pavement Mounted Snow/Ice Sensor

## LIMITED WARRANTY

ETI's two year limited warranty covering defects in workmanship and materials applies. Contact Customer Service for complete warranty information.

## DISCLAIMER

Environmental Technology, Inc. makes no representations or warranties, either expressed or implied, with respect to the contents of this publication or the products that it describes, and **specifically disclaims any implied warranties of merchantability or fitness for any particular purpose**. Environmental Technology, Inc. reserves the right to revise this publication, and to make changes and improvements to the products described in this publication, without the obligation of Environmental Technology, Inc. to notify any person or organization of such revisions, changes or improvements.