



Description

A maintenance-free, long life Hargrave's compressor has been instituted as an across the board replacement for the obsolete KNF pump in ADH-2A COM Dehydrators. The advantages of the new compressor are:

- Brushless motor for long life and zero maintenance.
- Hargraves' proprietary diaphragm material for longer life.
- Higher airflow at pressures above 2 PSI, similar airflow below 2 PSI.
- Smaller, lighter unit.
- More efficient design requires less power to operate.

This procedure documents the steps required to perform a field upgrade from the old pump to the new brushless unit.

Packing List

23031	Hargrave's Compressor Pump, small (QTY 1)
12522	Hex nut (QTY 4)
10378	Washer (QTY 4)
16979	Spacer (QTY 4)
17082	Cable tie (QTY 1)
23033	ADH-2A COM Pump Replacement Manual

LIMITED WARRANTY

ETI's two year limited warranty covering defects in workmanship and materials applies. Contact Customer Service for complete warranty information.

DISCLAIMER

Environmental Technology, Inc. makes no representations or warranties, either expressed or implied, with respect to the contents of this publication or the products that it describes, and **specifically disclaims any implied warranties of merchantability or fitness for any particular purpose**. Environmental Technology, Inc. reserves the right to revise this publication, and to make changes and improvements to the products described in this publication, without the obligation of Environmental Technology, Inc. to notify any person or organization of such revisions, changes or improvements.

Environmental Technology, Inc.

1850 N Sheridan Street • South Bend, IN 46628
(574)233-1202 • Fax (574)233-2152
Toll Free (800)234-4239 • Fax (888)234-4238
www.networketi.com • helpdesk@networketi.com

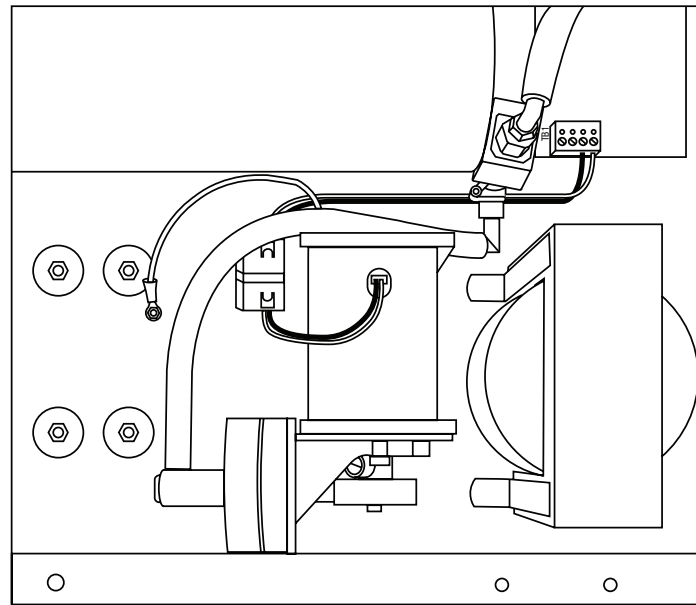

Step 1: Turn off unit and remove plug

Step 2: Remove top cover.

For rack mount units remove 12 screws.
For wall mount units remove 10 screws.

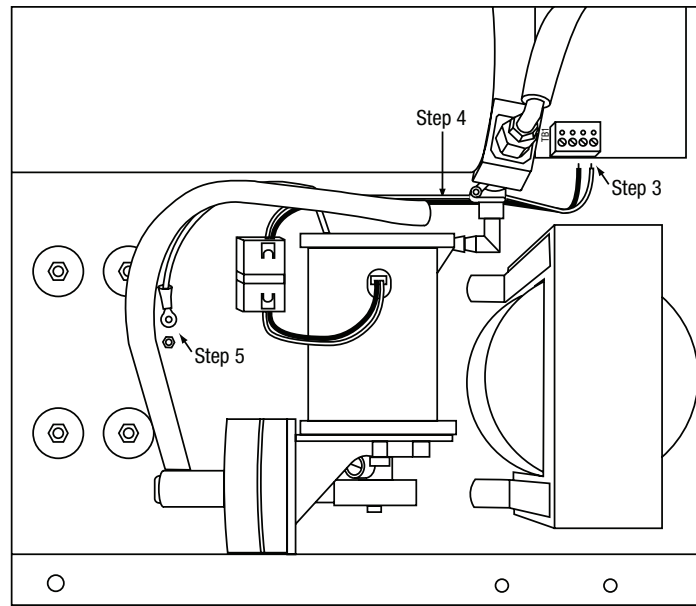

Step 3: Unscrew and remove red and black wires. If wires cannot easily be removed from ferrite core, cut cable tie and open core to remove wires. Reinstall core with enclosed cable tie after running new pump wires through it.

Step 4: Disconnect tubing from solenoid barbed fitting.

Step 5: Disconnect ground wire.

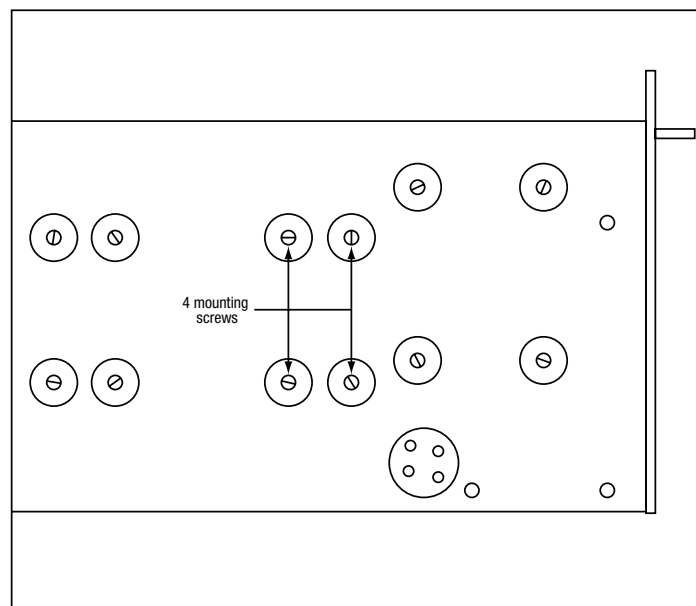

Step 6: Remove 4 mounting screws from back of unit (secure pump with other hand). Set 4 mounting screws and lock washers aside for use in re-installation.

Step 7: Remove screws, lock washers and nuts from second mounting position and replace them in the holes where original pump was located.

Step 8: Position Hargraves compressor over mounting holes and attach with screws, spacers, locking washers and nuts.

Step 9: Route red and black wires through ferrite core.



Your new DC brushless pump is polarized. Failing to wire as shown will damage the pump motor and can cause additional damage to your dehydrator.

Step 10: Insert red wire into Pin 4 of terminal. Insert black wire into Pin 3 of terminal.

Step 11: Connect air line tubing to solenoid barbed fitting.

Step 12: Reinstall cover.

Step 13: Reconnect power cord and turn on unit.

