



We manage heat ®

Model GIT-4

Gutter Snow and Ice Melting Control

Part Number 19556

Installation and Operation Manual

WARNING

Hazard of electrical shock.

Follow all safety procedures.

Any installation involving electric heater wiring must be grounded to earth to protect against shock and fire hazard. Suitable ground fault detection and interrupting systems must be in use at all times to reduce shock and fire hazard and to protect equipment.

Electric wiring to heating elements must be installed in accordance with Article 110.3B, Article 210.8(A)(3), Article 250.4(A), Article 426.4 & 28, Article 725.55 and all other applicable sections of the National Electric Code (NFPA 70), local electrical codes, and any third party standards.

Only qualified personnel trained in electrical equipment service should perform maintenance on heating and control equipment.

Environmental Technology, Inc.

1850 N Sheridan Street

South Bend, Indiana 46628

(574) 233-1202 or (800) 234-4239

FAX (574) 233-2152 or (888) 234 4238

www.networketi.com

DISCLAIMER

Environmental Technology, Inc. makes no representations or warranties, either expressed or implied, with respect to the contents of this publication or the products that it describes, **and specifically disclaims any implied warranties of merchantability or fitness for any particular purpose.** Environmental Technology, Inc. reserves the right to revise this publication and to make changes and improvements to the products described in this publication without the obligation of Environmental Technology, Inc. to notify any person or organization of such revisions, changes or improvements.

Copyright © 2003 Environmental Technology, Inc. All rights reserved. No part of this manual may be reproduced or translated in any form or by any means, electronic or mechanical including photocopying and recording, for any purpose without the express written consent of Environmental Technology, Inc.

The ETI logo and We Manage Heat are registered trademarks of Environmental Technology, Inc.
GIT is a trademark of Environmental Technology, Inc.

Description

The computerized UL and CUL Listed GIT-4 automatically controls gutter and downspout snow and ice melting heaters. It is safety tested to Standard 873 for Temperature Indicating and Regulating Equipment. The GIT-4 includes the GFEP (ground fault equipment protection) required by the NEC.

The GIT-4 consists of sensor and control assemblies connected by a 12' (3.6 m) cable. The sensor meets the NEC (National Electrical Code) low voltage Class 2 requirement for wet locations.

The GIT-4 requires an RCU-2 Remote Control Unit which is included. The RCU-2 provides remote control and monitoring of the GFEP function. It also permits operating the snow and ice melting heaters for a fixed time at temperatures below 38° F (3.3° C).

Supply Voltage Options

The GIT-4 provides jumper-selected supply voltage options of 120, 208 through 240, and 277 volts. Selecting the proper supply voltage is very important. An incorrect setting may destroy the GIT-4 or render it inoperative. The GIT-4 operates from the heater supply voltage.

Relay (Contactor) Contact Ratings

The relay (contactor) provides a Form A (SPST) contact rated for up to 26 amp AC heater loads at voltages at or below 277 volts.

Safety

Any installation involving electric heater wiring must be grounded to earth to protect against shock and fire hazard. Suitable ground fault detection and interrupting systems must be in use at all times to reduce shock and fire hazard and to protect equipment.

Electric wiring to heating elements must be installed in accordance with Article 110.3B, Article 210.8(A)(3), Article 250.4(A), Article 426.4 & 28, Article 725.55 and all other applicable sections of the National Electric Code (NFPA 70), local electrical codes, and any third party standards. Follow the installation instructions contained herein and those provided by the heater manufacturer. If you have questions concerning the installation contact Customer Service for assistance.

The use of a GIT-4 with integral GFEP satisfies the NEC requirement for GFEP on each branch circuit connected to the snow and ice melting system. Clearly label each circuit breaker with its function. This is vitally important when there is more than one point of disconnect.

Make certain that the heater shield is properly grounded as required by the NEC.

Installing the Sensor

Mount the sensor as low as possible in the gutter about a foot upstream of the downspout. For proper operation, the heating cable must be close to but not touching the sensor. A separation of $\frac{1}{2}$ " (1.3 cm) to 1" (2.5 cm) is ideal. Orient the sensor with the temperature sensor facing upstream and the moisture sensor toward the down spout. Use the supplied plastic mounting straps and gasketed #10 fasteners to secure the sensor in the gutter via $\frac{3}{16}$ " drilled holes through the gutter. See Figure 1.

Installing the Control

Lethal voltages are present within the control enclosure during operation. Some installations may require two points of disconnect. Tag all circuit breakers off during installation or service.

The GIT-4 comes factory set for 277 volt operation. A jumper located in the control must be changed for 120 or 208 through 240 volt operation. See Figure 2. An incorrect setting may destroy the GIT-4 or render it inoperative.

The control comes connected to the sensor with 12 feet (3.6 meter) of three conductor cable. The snow and ice melting heater leads, supply leads and sensor leads terminate in the control enclosure. Locate the control enclosure outdoors at a place convenient for the wiring connections. Position the control housing so that the sensor cable entry is positioned at the right of the housing, heater leads exit to the left and the supply leads enter at the bottom. Failing to orient the housing correctly may cause moisture collection in the housing resulting in equipment damage.

For line supply and load connections use #10 AWG or larger wires rated for at least 194° F (90° C). Figures 4 and 5 show wiring for typical 120/240 volt residential applications and unbalanced 208 or 277 3-phase applications.

Installing the RCU-2

The RCU-2 is an NEC Class 2 device. It can be located up to 150 feet (46 meters) from the control. Use customer supplied #18 AWG 2-conductor jacketed cable.

Choose a convenient protected indoor location. The RCU-2 mounts in a single gang switch box. The wiring connections to the RCU-2 are not polarity sensitive and connect to the two blue wires in the low voltage section of the control enclosure.

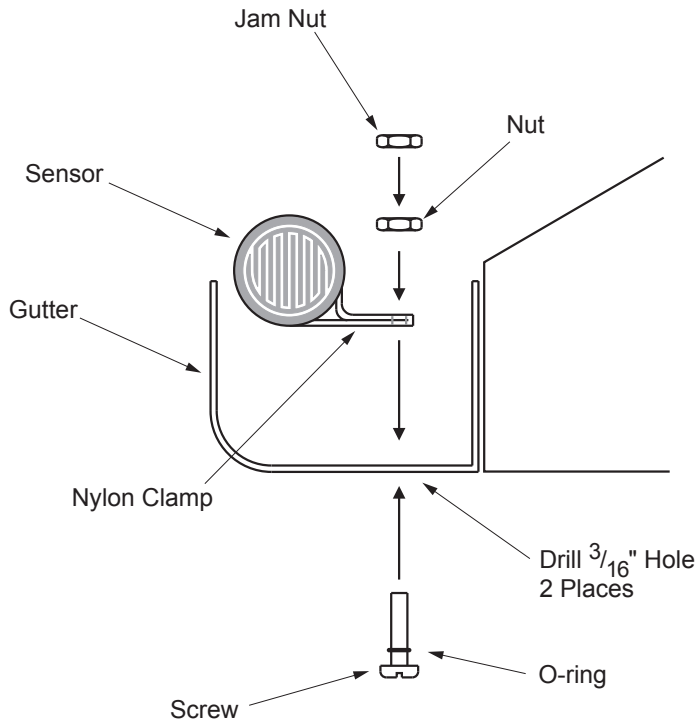

Figure 1. Sensor mounting

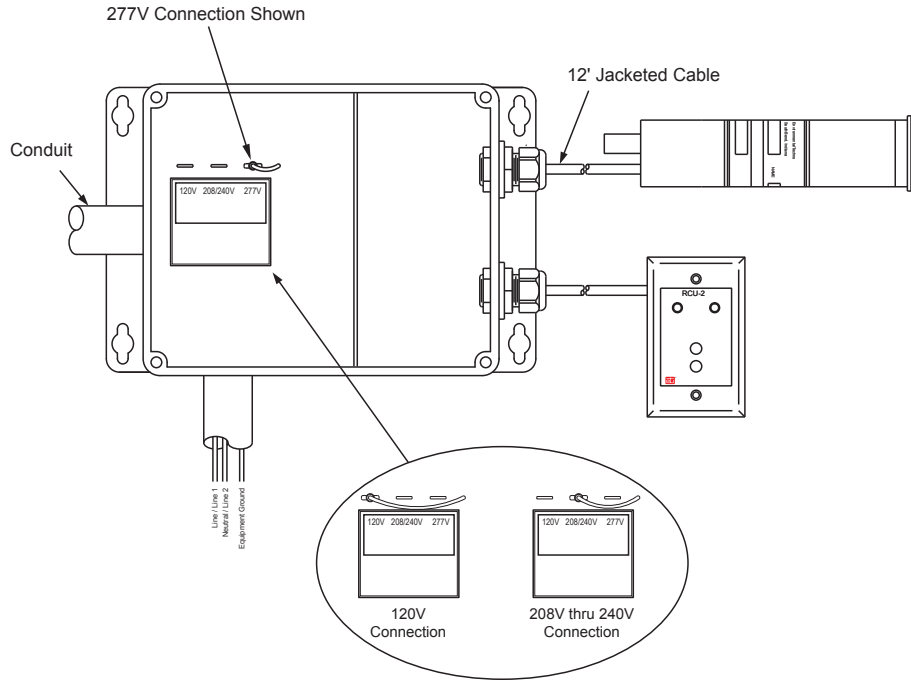

Figure 2. Selecting Voltage

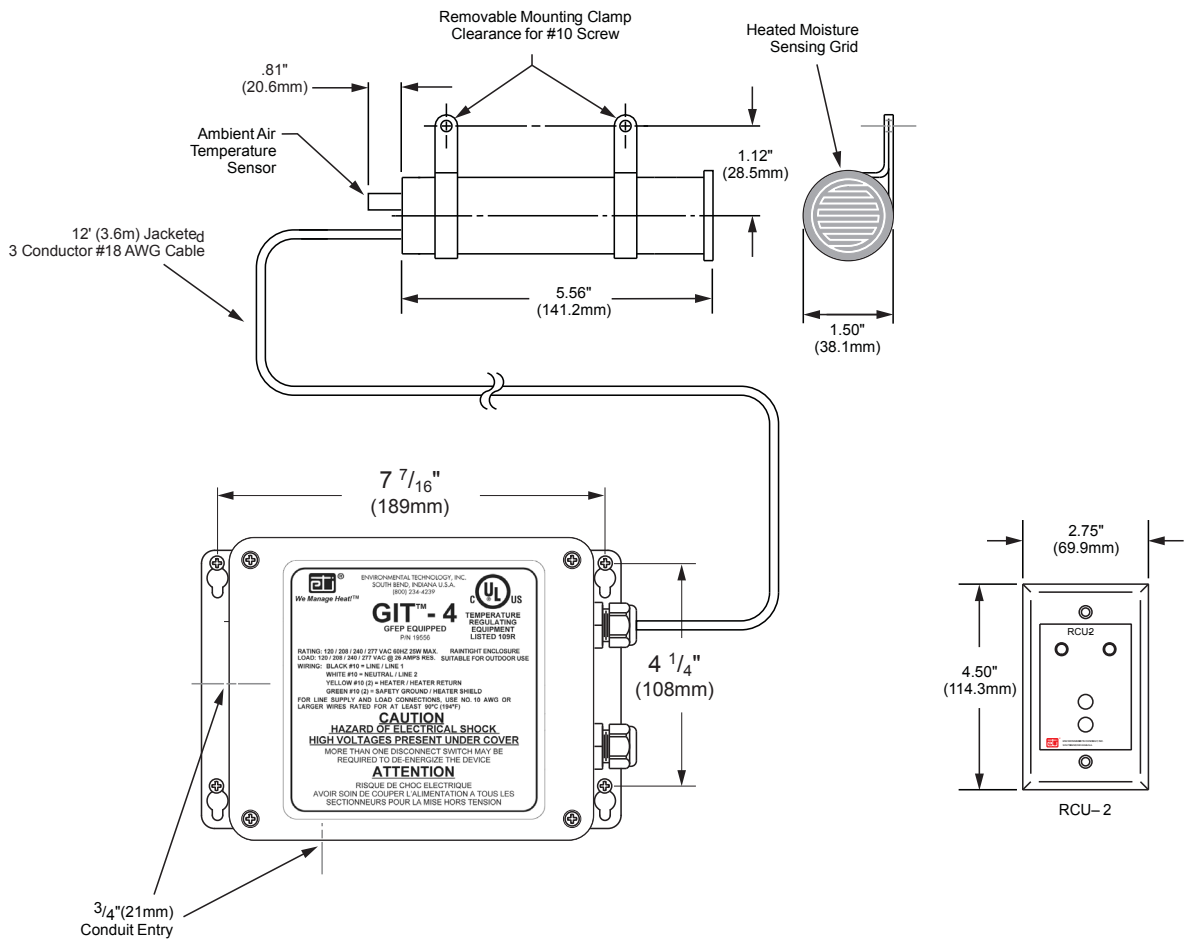

Figure 3. Mounting Dimensions

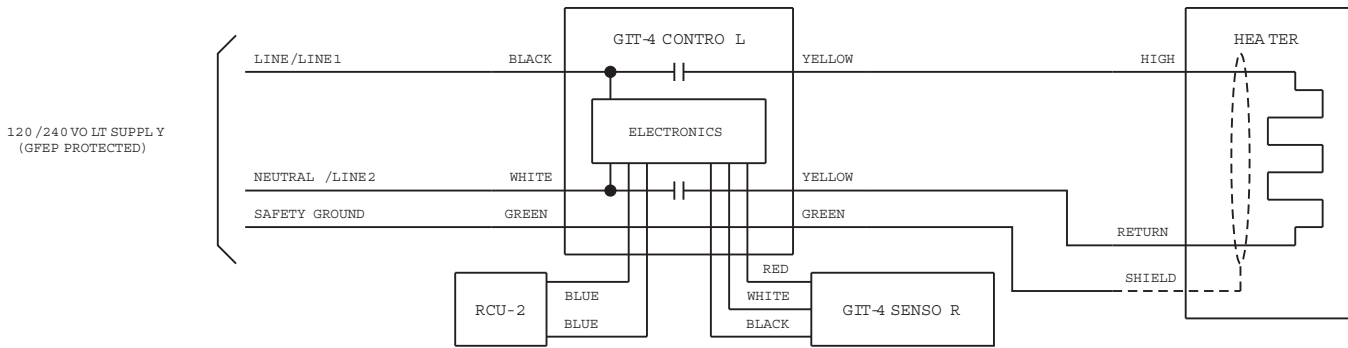

Figure 4. Typical 120/220 Volt Residential Applications

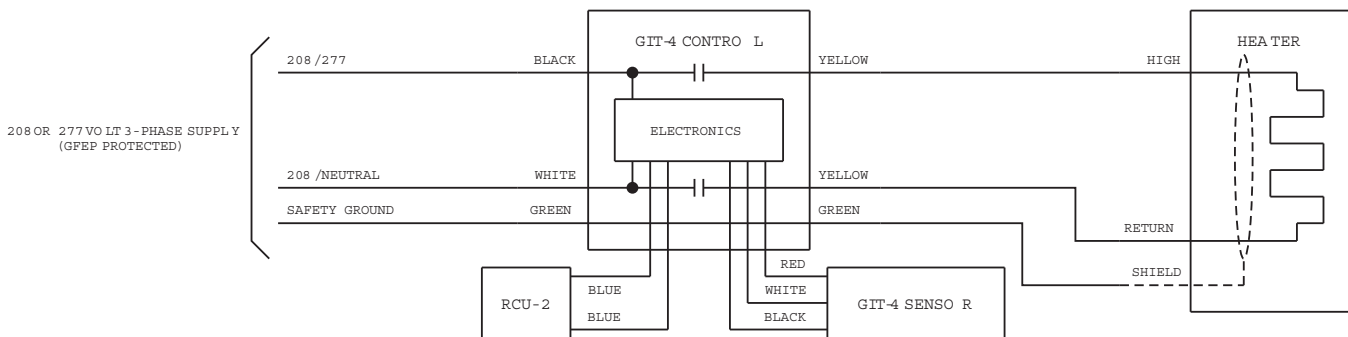

Figure 5. Unbalanced 208 or 277 3-Phase Applications

Post Installation Tests

Thoroughly check the system before placing it in service. Our experience shows that installation errors cause the majority of problems. Frequently encountered problems include wiring errors and improper waterproofing. Simple electrical tests and visual inspections identify these problems.

Checking the sensor in the field is not practical. Verifying its operation requires special test equipment that is neither portable nor commonly available.

Checking the operation of the control requires a clamp-on AC ammeter. Follow the steps below to verify operation. The gutter and downspout must be dry while doing these tests.

1. Remove power from the snow and ice melting system. There may be two points of disconnect.
2. Clamp the ammeter to one of the yellow leads in the control housing.
3. Locate the probe connections in the low voltage compartment. Remove the wire nuts from the black leads and white leads. Make certain the same color wires remain twisted together and that the two black and two white wires don't touch electrically.
4. Apply power to the snow and ice melting system. This may require two points of connection. Use care. Lethal voltages are now present within the control enclosure. The ammeter should read approximately zero amps.
5. Remove power from the snow and ice melting system. There may be two points of disconnect.
6. Using a wire nut, temporarily connect the two black and two white wires together.
7. Apply power to the snow and ice melting system. This may require two points of connection. Use care. Lethal voltages are now present within the control enclosure. The ammeter should read the nominal heater current.

8. Immediately remove power from the snow and ice melting system. There may be two points of disconnect.
9. Make certain that the two black probe leads are securely connected together electrically. Secure these wires with a wire nut.
10. Make certain that the two white probe leads are securely connected together electrically. Secure these wires with a wire nut.

Operating Instructions

The GIT-4 does not require user intervention during normal operation. The green SUPPLY indicator operates to show that power is applied to the system. The yellow HEATER indicator operates while the heaters are operating or enabled to operate.

In some installations drifting and blowing snow may present a problem if this does not occur at the sensor. In this case, press the HEATER CYCLE switch to energize the heaters for one hour to melt accumulated snow. Repeat as required after each one hour period until accumulated snow and ice are melted.

Semi-monthly Routine Testing

Press the TEST/RESET switch to test the GIT-4 GFEP for proper functioning. The SUPPLY and HEATER indicators flash alternately for a few seconds during testing. The RCU-2 flashes these indicators if the test fails. Pressing the TEST/RESET switch will not clear this condition. If the test fails, the GIT-4 will not operate the snow and ice melting system heaters. You need to have a qualified electrician fix the problem.

If the snow and ice melting system is operating normally, there is no need for this test. Press the HEATER TOGGLE switch momentarily. The HEATER indicator should operate. After a few seconds, press the HEATER TOGGLE switch again. The HEATER indicator should turn off. If the SUPPLY and HEATER indicator flash alternately, a GFEP failure exists. You need to have a qualified electrician fix the problem.

Maintenance

Although the GIT-4 does not require routine maintenance, make certain that the gutters and down spouts are cleaned each fall to ensure efficient gutter and down spout snow and ice melting system efficiency.

For technical help, questions or comments concerning this product or any Environmental Technology, Inc. products contact the Customer Service Department between 8:00am and 5:00pm EST (UTC minus five hours) at:

Voice: 800.234.4239 (USA and Canada) or 574.233.1202 (elsewhere)

Fax: 888.234.4238 (USA and Canada) or 574.233.2152 (elsewhere)

E-mail: helpdesk@networketi.com