



# EDH™-4 Air Dehydrator

Part Number: Rack Mounted 18021  
Wall Mounted Adapter 17982  
NEMA 18250  
August 1998

## **ENVIRONMENTAL TECHNOLOGY, INC.**

1850 N SHERIDAN STREET, SOUTH BEND, IN 46628 USA

(574) 233-1202

FAX (574) 233-2152

Toll Free (800) 234-4239

Toll Free FAX (888) 234-4238

<http://www.networketi.com>

email: [helpdesk@networketi.com](mailto:helpdesk@networketi.com)

**DISCLAIMER**

Environmental Technology, Inc. makes no representations or warranties, either expressed or implied, with respect to the contents of this publication or the products that it describes, and specifically disclaims any implied warranties of merchantability or fitness for any particular purpose. Environmental Technology, Inc. reserves the right to revise this publication, and to make changes and improvements to the products described in this publication, without the obligation of Environmental Technology, Inc. to notify any person or organization of such revisions, changes or improvements.

The ETI Logo is a registered trademark of Environmental Technology, Inc.  
EDH and ADH are trademarks of Environmental Technology, Inc.

Copyright ©1998 by Environmental Technology, Inc.

**Printed in USA**

All rights reserved. No part of this manual may be reproduced or transmitted in any form or by any means, electronic or mechanical, including photocopying and recording, for any purpose without the express written consent of Environmental Technology, Inc.

**Abnormal Odor or Smoke**

In the event of smoke or an abnormal odor, immediately interrupt power to the EDH-4 with the POWER switch at the rear of the unit, unplug the unit, or trip the circuit breaker controlling the outlet.

**Lethal Voltages Present**

There are lethal voltages present inside the case of the EDH-4. Service should be performed by qualified personnel only. There are no user serviceable components inside the chassis.

**Pneumatics**

The air pump in the EDH-4 is capable of generating as much as 1.2 psig (82.7 mbar). Proper safety practice requires treating all pneumatic components with care. Always vent the system to atmospheric pressure before servicing pneumatic components.

**Rack Mounting**

Before rack mounting the EDH-4 ensure that rack is stable. Verify adequate air flow and power supply capacity is available to the unit. Ensure that EDH-4 maximum operating temperature of 130°F(55°C) will not be compromised by other components in rack. Ensure reliable earthing of EDH-4.

**Environmental Technology, Inc.**

# Contents

<b>Introduction</b> .....	<b>7</b>
Purpose .....	7
Description .....	7
<b>Installation</b> .....	<b>8</b>
Unpacking/Packing.....	8
Inventory List .....	8
Initial Inspection .....	8
Location .....	9
Principal Considerations .....	9
Power Connection .....	9
Pneumatic Connection .....	11
<b>Operation</b> .....	<b>11</b>
Controls .....	11
Indicators .....	11
<b>Operating Procedures</b> .....	<b>12</b>
Automatic Operation .....	12
Alarm Relays.....	12
<b>Emergency Procedures</b> .....	<b>12</b>
Abnormal Smoke or Odor .....	12
Ruptured feed window .....	12
<b>Technical Description</b> .....	<b>13</b>
Electronic .....	13
Pneumatic .....	13
Theory of Operation.....	13
<b>Maintenance</b> .....	<b>13</b>
Periodic Maintenance .....	13
Renewing the Desiccant .....	14
Returns and Replacement Parts Purchases .....	14
Troubleshooting .....	15
<b>Appendix A. Specifications</b> .....	<b>17</b>
<b>Appendix B. Alarms</b> .....	<b>18</b>



## Introduction

### Purpose

Unpressurized dielectric transmission lines allow the entry of moist ambient air through leaking seals, penetrations and cracks. When the line passes from one environment to another (such as when entering a shelter from the antenna outside) or when there is a change in existing environmental conditions (such as a weather front, or nightfall) the pressure and/or temperature changes in the air will result in the collection of water. This is normally the result of the ambient temperature dropping below the dew point. Water in transmission lines causes corrosion, voltage arcing and increased VSWR. These conditions reduce system performance.

The EDH-4 Low Cost Air Dehydrator prevents the accumulation of moisture in dielectric lines by maintaining the pressure and humidity of the air in the line. Supplying low pressure dry air, the EDH-4 keeps waveguides, air dielectric coaxial cable and other related components used in earth station and terrestrial UHF and microwave communication systems dry. The EDH-4 is intended for use in small volume C, X, Ku, and Ka band applications. For larger applications please contact Customer Service for information on ADH-2A COM and ADH-3COM Automatic Dehydrators.

### Description

The EDH-4 is a nonregenerative air dehydrator. Air is pressurized by a twin piston type pump and then dehydrated by passing it through an absorption unit containing a drying agent. The dried air is then delivered to the communications equipment through a 1/4" hose barb fitting on rack and wall mount units and through a 1/8" NPT female fitting on the NEMA unit. The moisture is removed from the drying agent manually (*see "Renewing the Desiccant", pg. 14*). The EDH-4 provides dry air regulated between 0.3 psig (20.7 mbar) to 0.5 psig (34.5 mbar) and is capable of delivering 6 cubic feet of air per hour (2.8 l/m). Under normal conditions, the maximum dew point of the air is -40°C and nominally -70°C.

Physically, the EDH-4 occupies three spaces of a standard relay rack. No other peripheral equipment is required on rack mount units. Wall mount units include "Z" brackets to attach the rack panel to the wall. NEMA units ship mounted in a NEMA 3R enclosure.

Pressure display is user selectable to SI or English customary units. Both pressure and alarm information are shown on a wide viewing angle LED digital display. The EDH-4 makes use of two alarm relays. The first alarm relay is a renew desiccant alarm, the second alarm relay indicates one or more summary alarms. The desiccant blend contains a blue silica gel which turns pink when the desiccant requires renewal.

Users may elect to renew the drying agent as required — typically every six months to two years depending on system leakage and environmental conditions.

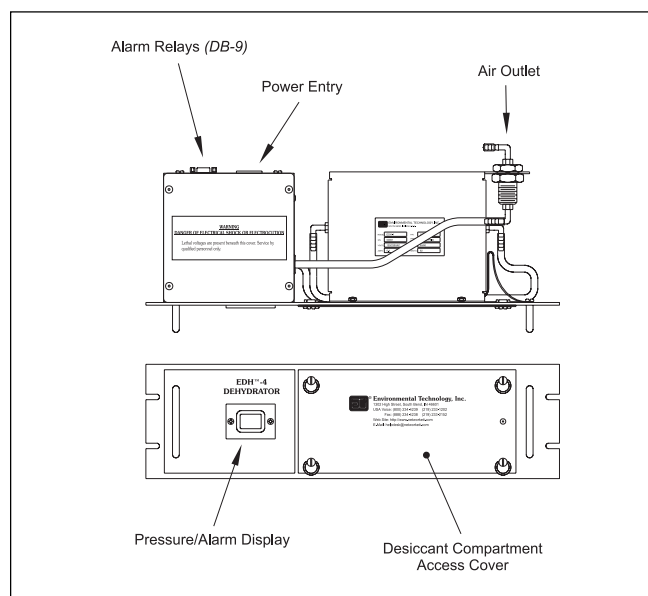

Figure 1. EDH-4 components

## Installation

### Unpacking/Packing

Immediately inspect the shipping container and packing material for damage. Unpack the EDH-4, taking care not to damage the cushioning materials. Save the shipping container and related materials until normal operation has been established. If the unit must be returned, take care to ensure that it is repackaged as it was received.

### Inventory List

Verify the package contains the parts listed for EDH-4 version ordered.

#### Rack Mount

Qty.	Part Number	Description
1	18021	EDH-4 Dehydrator
1	18063	EDH-4 Instruction Manual

#### Wall Mount

Qty.	Part Number	Description
1	18021	EDH-4 Dehydrator
1	17982	EDH-4 Wall Mount Adapters
1	18063	EDH-4 Instruction Manual

#### NEMA

Qty.	Part Number	Description
1	18250	EDH-4 NEMA
1	18063	EDH-4 Instruction Manual

Additional equipment required for installation:

- **Tubing and Fittings.** The EDH-4 comes equipped standard with a 1/4" hose barb fitting which accepts 1/4" I.D. flexible tubing. On NEMA units a 1/8" NPT female fitting is used. Special fittings and tubing can be purchased from ETI, contact Customer Service for details.

### Initial Inspection

Inspect the EDH-4 for electrical and mechanical damage. If any of the following problems are found contact the Customer Service Department.

- **Contents incomplete or incorrect**
- **Internal or external mechanical damage**
- **Defective operation**

Customer service is available between 8:00 a.m. and 5:00 p.m. EST (UTC minus 5 hours) at 574-233-1202 or 800-234-4239. In the



event of shipping damage, keep the packing materials for inspection by the carrier. Normally, Environmental Technology, Inc. will repair or replace the EDH-4 without waiting for the claims settlement.

## Location

The rack mounted EDH-4 requires a relay rack panel space of 19 inches by 5-1/4 inches (*see Figure 2*). As the EDH-4 seldom requires operator attention, a location in the lower portion or extreme upper portion of the relay rack should be considered.

The wall mount version requires an area of approximately 6 inches high by 24 inches wide (15 cm by 61 cm) and will project almost 10 inches (25.4 cm) from the wall. The NEMA version requires an area of approximately 13 inches high by 24.5 inches wide (33 cm by 62.2 cm) and will project about 12.5 inches (31.8 cm) from the wall. Plan your installation so that the EDH-4 will not interfere with normal traffic patterns at your site. Ensure the mounted unit will have sufficient clearance around the unit to facilitate access to the power, alarm relay and pneumatic connections. The mounting brackets will accommodate fasteners up to 1/4 inch (6.3 mm) in diameter. The choice of anchors and companion hardware should be appropriate for the mounting surface. At least four anchors should be used and each should be capable of supporting a combined load of at least 5 pounds (2.4 kg) for a wall mounted unit. Mounting anchors for a NEMA unit should be capable of supporting a combined load of at least 48 pounds (24 kg). The location of the mounting points is shown in Figure 3.

**Note:** *This unit produces a slight vibration due to rotating components. This may lead to fatigue and possible failure of the mounting system or wall material. Please consider this when planning your installation.*

**Note:** *The EDH-4 NEMA is permanently connected equipment and does not have a quick disconnect device. A readily accessible disconnect device and a short circuit and overcurrent device rated 20 amps maximum should be provided in the building.*

## Principal Considerations

The EDH-4 works best supplying dry air in a flowing system, where the dehydrator completely replaces the air on a regular basis. Consequently, the equipment being supplied dry air should be *slightly leaky*. For a waveguide, this is best accomplished by slightly opening a purge valve at the window end of the system. Likewise, air dielectric coaxial cable should be equipped with a valve at the far end which can be set to allow a small leak. Many systems will have sufficient normal leakage that such actions will be unnecessary.

The EDH-4 also has check valves in the air path. A tightly sealed system may experience a pressure increase with a rise in ambient temperature. The unit has no way to reduce such a pressure buildup.

## Power Connection

The EDH-4 operates from either 120 Vac or 230 Vac at 50/60 Hz. An internal line operated relay sets circuitry to operate from the proper supply voltage. This eliminates the need to set voltage during the installation or having to purchase different units for different power requirements.

The EDH-4 rack and wall mount units require a standard outlet (North American: NEMA 5-15R) no further than 6' (1.8 m) from the power entry point at the back of the unit. The EDH-4 NEMA unit requires a permanent connection and requires a quick disconnect device. A readily accessible disconnect device and a short circuit and overcurrent device rated 20 amps maximum should be provided in the building. A 0.875 inch (22.2 mm) hole is provided in the bottom of the NEMA enclosure for a conduit connection for supplying electrical power. Ensure conduit connection is suitable for preventing the accumulation

**Environmental Technology, Inc.**

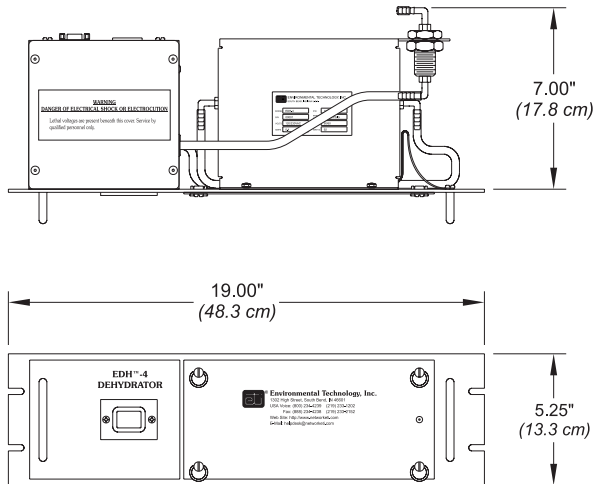

Figure 2. Rack mounting dimensions

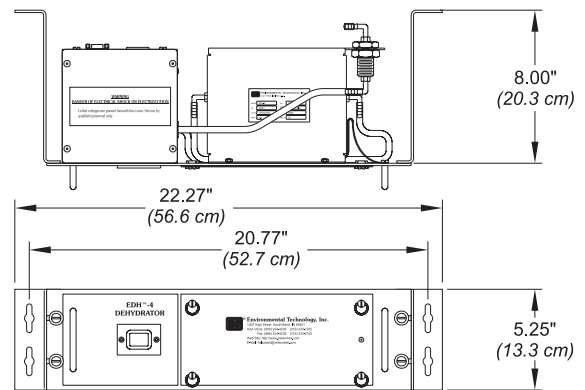

Figure 3. Wall mounting dimensions

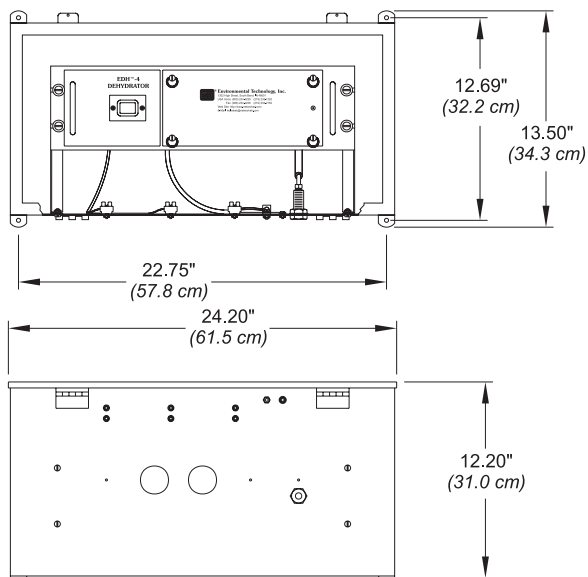

Figure 4. NEMA mounting dimensions

of water and dust within the enclosure. The EDH-4 does not incorporate a power switch and the unit will be energized as soon as power is connected to the unit. The power cord contains a ground lead, but it is recommended that the unit also be connected to true earth ground using the lug next to power entry module.

### **Pneumatic Connection**

Rack and wall units are supplied with a 1/4" barbed male fitting. Slip the supply tubing over the outlet barb engaging all the ridges. The fit should be tight enough that a clamp or cable tie is not required although its use is recommended. The NEMA unit provides a 1/8" NPT female fitting at the bottom of the unit. Special accessories including distribution manifolds, a variety of pressure fittings and tubing are available from Customer Service.

## **Operation**

### **Controls**

The EDH-4 makes use of only a single switch. The switch is located inside the desiccant bottle enclosure. This switch allows the user to change display units, to display percentage of time left until the desiccant should be renewed, and to reset the time for the renew desiccant timer.

### **Indicators**

The front panel display is composed of two digits that show pressure and status information. Pressure may be displayed in either English customary units or SI units, with English being the default. The display units may be switched by depressing the push-button switch just inside the desiccant enclosure when applying power to the unit. While units are set to English customary no decimal point is displayed, i.e. the unit will display 99 for 0.99 psig, the maximum displayable pressure in English customary units. The maximum displayable pressure while in SI units is 99 mbar.

In the event of an alarm condition, an alarm code will be displayed (*see Table 1.*) If no alarms exist only system pressure will be displayed.

The front panel display may also be used to display percent of time till the desiccant regeneration timer will trigger an alarm condition. To display the timer momentarily depress the push-button just inside the desiccant enclosure while power is on. To reset the timer hold push-button in for more than 5 seconds.

<b>Display</b>	<b>Alarm</b>
CC	Desiccant Renewal
HF	Low Temperature
FF	Leaky System
F1	Low Pressure
un	Initialization Error

*Table 1. Alarm codes*

## Operating Procedures

### Automatic Operation

The EDH-4 will commence operation when power is applied. The unit will automatically regulate the system pressure between 0.3 psig (20.7 mbar) and 0.5 psig (37.5 mbar).

### Alarm Relays

Two alarm relays are available through a DB-9 female connector located on the rear of the EDH-4 (see Table 2. for pin out definition). One of the alarm relays is a summary alarm and closes when any of the following conditions are met:

1. Low temperature with in electronics housing; internal temperature falls below 0°C.
2. Excessive run time; the pump runs continuously for more than four hours.
3. Low pressure; the system pressure falls below 0.20 psig (13.8 mbar) for 25 continuous seconds.

The summary alarm will continue as long as any of these conditions exist. When all conditions have been cleared the alarm will reset. The second alarm relay closes when the renew desiccant timer signals a need to replace or regenerate desiccant. This alarm is reset by depressing the push-button inside the desiccant enclosure and holding for more than five seconds. Both relays close at power off.

Pin	Description
1	Desiccant Alarm Relay Normally Open
2	Desiccant Alarm Relay Normally Closed
3	Not used
4	Summary Alarm Relay Normally Open
5	Summary Alarm Relay Normally Closed
6	Desiccant Alarm Relay Common
7	Not used
8	Not used
9	Summary Alarm Relay Common

Table 2. Alarm relay connector pin assignments

## Emergency Procedures

### Abnormal Smoke or Odor

Immediately interrupt the power to the unit by unplugging the unit or by tripping the breaker on the power circuit. The transformer contains fuse links that operate in the event of excessive current or temperature.

### Ruptured feed window

A ruptured feed window makes it impossible to maintain pressure in the system. In addition, this condition makes it possible for water to flow into the dehydrator in the event of heavy rain. If this problem occurs, immediately remove power from the unit. The outlet check valve will prevent back flow into the unit.

The EDH-4 will stop trying to pressurize a system if the compressor runs for 4 hours continuously. To restore normal operation, momentarily interrupt power to the unit.

# Technical Description

## Electronic

The power supply in the EDH-4 makes use of an automatic voltage sensing relay. This internal line operated relay sets circuitry to operate at the proper supply voltage.

The EDH-4's processor consists of a single integrated circuit that requires almost no support circuitry. The processor controls pump operation to regulate system pressure, monitors electronics enclosure temperature, and monitors compressor run time. The device carries the control software in onboard ROM. The front panel LED display is controlled by a device driver which receives display information from the processor. An onboard EEROM is used to accumulate compressor run time and to store display mode.

## Pneumatic

The pneumatic system from the pump to the unit's outlet operates at the system pressure. The air pump is a twin piston type compressor. Air is drawn into the pumps, compressed, and delivered to the system. After passing through the absorption unit, the air passes through a check valve. The check valves prevents reverse flow through the pump and ensures that pressure is maintained even in the event power is lost. The dried air is then delivered to the outlet.

## Theory of Operation

The EDH-4 consists of a control loop controlling system pressure and a second loop monitoring run time since desiccant replacement or regeneration. The pressure control loop is composed of the air pump, the pressure transducer and the main microprocessor. The outlet pressure is monitored. When the pressure drops to the low limit, the air pump is started and system pressure increases until the processor obtains a high limit reading from the transducer. At this point the pump is stopped and the loop is complete.

The running time for the compressor is accumulated and stored in the EEROM. When 1,000 hours have been recorded, a Renew Desiccant alarm is issued to indicate a need to regenerate or replace the desiccant.

# Maintenance

## Periodic Maintenance

The EDH-4 uses a granular desiccant blend consisting of white activated alumina and blue silica gel. The silica gel granules turn light pink when spent to indicate the need to renew the desiccant. The renew desiccant alarm appears when 1,000 hours has been accumulated on the pump. Normally the desiccant requires renewal every 12 to 18 months. The exact interval depends on system tightness and environmental conditions. Monthly visual inspection of the desiccant is recommended.

The EDH-4 requires no preventive maintenance.

## **Renewing the Desiccant**

**Safety Note:** *Servicing should be left to qualified personnel. The desiccant used in the EDH-4 Dehydrator is an inert compound of aluminum and oxygen. Care should be taken to prevent the dust from entering the respiratory tract or the eyes. Utilize proper eye protection and respirator while servicing. The unit may produce as much as 1.2 psig (82.7 mbar) under worse case failure. Vent the system to atmosphere before servicing pneumatic components.*

The desiccant bottle on the EDH-4 is accessible through the front panel. To access the desiccant, turn each of the four D-rings a quarter turn counterclockwise and remove access cover. Slide bottle forward until tubing can be removed and remove tubing before completely removing the bottle from the unit. After tubing is removed, remove the desiccant bottle from the unit and remove bottle cap. This may require some force. Remove grey foam filter from the bottle, taking care not to tear or otherwise damage the filter. If necessary, dry the filter. Save the filter for reinstallation.

If replacing the desiccant, properly dispose of old desiccant. If regenerating desiccant empty desiccant into clean baking dish. Bake desiccant at 350° for two hours, or until silica gel particles turn dark blue, in a conventional oven (**do not** use a microwave). After silica gel particles have turned dark blue, remove desiccant from oven and allow desiccant to cool to room temperature. Desiccant should either be returned to the EDH-4's desiccant bottle or placed in another airtight container as soon as it reaches room temperature to prevent the collection of moisture from surrounding air.

Fill the bottle with the new or regenerated desiccant. Reinstall grey foam filter. Reinstall the original bottle cap taking care not to disturb the adapter fitting. Both adapter fitting and bottle top should be secured tightly to prevent leakage which may lead to reduced desiccant service life. Slide bottle slightly back into compartment and reattach tubing. Slide remainder of bottle into the compartment. Reset the Renew Desiccant timer by depressing the push-button just inside the compartment and holding for more than five seconds while power is on to the unit. Reinstall access cover.

## **Returns and Replacement Parts Purchases**

Before returning the unit to Environmental Technology, Inc., obtain a return authorization number from our Customer Service Department between 8:00 AM and 5:00 PM EST (UTC minus five hours) at 574-233-1202 or 800-234-4239. With a return authorization number your EDH-4 can be returned. Use the original cushioning materials when packing the EDH-4 for shipment if possible.

Replacement parts list

<u>P/N</u>	<u>Description</u>
18138	Replacement Desiccant

## Troubleshooting

<b>Problem</b>	<b>Action</b>
<b>Nothing works</b>	<p><b>Verify the unit has power.</b></p> <p>Ensure supply power is available to the unit.</p>
<b>Low Pressure</b> (Alarm F1)	<p><b>Disconnect feed tube from air outlet.</b></p> <p>Pump should operate continuously.</p> <p>No pump operation.</p> <p>Check pump electrical connections.</p> <p>Pump has failed.</p> <p>Circuit board has failed.</p> <p><b>Plug air outlet.</b></p> <p>Unit reaches correct operating pressure.</p> <p>Check communication equipment for leaks.</p> <p>Continued low or no pressure.</p> <p>Check internal air path for leaks or blockage.</p> <p>Check air flow through pump inlet filter.</p> <p>Pump has failed.</p> <p>Circuit board has failed.</p>
<b>Leaky System</b> (Alarm FF)	<p><b>Check unit pressure.</b></p> <p>Pressure reads less than 0.2 psig (16.8 mbar).</p> <p>Check internal air path for leakage.</p> <p>Check communication equipment for excessive leakage.</p> <p>Pressure reads more than 0.5 psig (37.5 mbar).</p> <p>Check air path inside unit for blockage.</p> <p>Circuit board has failed.</p>
<b>Low Temperature</b> (Alarm HF)	<p><b>Verify electronic enclosure temperature above 0°C.</b></p> <p>If equipment room temperature is below 0°C allow the unit to run 30 - 60 minutes to allow enclosure heaters to raise internal temperature.</p> <p>Circuit board has failed.</p>

**Troubleshooting** *(Continued)*

---

<b>Problem</b>	<b>Action</b>
<b>Desiccant Renewal Required</b> (Alarm CC)	<b>Visually inspect desiccant bottle.</b>  Silica gel particles in desiccant are blue.  Reset desiccant alarm by depressing and holding for more than five seconds the push button just inside the desiccant compartment.  Silica gel particles in desiccant are pink.  Renew desiccant, refer to “Renewing the Desiccant” in the Maintenance section of this manual.
<b>Initialization Error</b> (Alarm un)	Circuit board has failed.



## Appendix A. Specifications

Designation	EDH™-4 Low Cost Air Dehydrator
Part Number	18021 (Rack Mount), 17982 (Wall Mount), 18250 (NEMA)
Dimensions	19" x 5.25" x 7" (48.3 cm x 13.3 cm x 17.8 cm) (Rack Mount) 22.27" x 5.25" x 8" (55.6 cm x 13.3 cm x 20.3 cm) (Wall Mount) 24.2" x 13.5" x 12.2" (61.5 cm x 34.3 cm x 31 cm) (NEMA)
Weight	Approximately 5 pounds (2.4 kg) (Rack and Wall Mount) Approximately 48 pounds (24 kg) (NEMA)
Storage temperature	-40°F to 150°F (-40°C to 60°C)
Operating temperature	-40°F to 130°F (-40°C to 55°C)
Mounting method	Standard relay rack mount (3U) or wall mount
Air discharge pressure	0.5 psig (34.5 mbar)
Pressure range	0.3 to 0.5 psig (20.7 to 34.5 mbar)
Discharge port	1/4" (6.4 mm) hose barb (Rack and Wall Mount) 1/8" NPT female fitting (NEMA)
Number of discharge ports	1
Air pressure indication	Digital display (psig SI)
Air discharge flow rate (max.)	6 cu ft/hr (2.8 l/min)
Maximum dew point	-40°F (-40°C)
Regeneration method	Manual, demand
Power requirements	92 VA maximum
Supply voltage	120/230 VAC, 50 or 60 Hz
Data displays	Pressure, Error Codes
Alarm relay capacity	2 Amp @ 30 Vdc
Relay connection	DB-9 female connector
Reliability	MTBF – 100,000 hours

## **Appendix B. Alarms**

<b>Display</b>	<b>Meaning</b>
CC	Desiccant renewal: Compressor timer has accumulated 1,000 hours.
HF	Low temperature: Electronic enclosure internal temperature below 0°C.
FF	Leaky system: Compressor runs continuously for more than four hours.
F1	Low pressure: Unit pressure below 0.2 psig (13.8 mbar).
un	Initialization error: Failed memory check during initialization.